

INSTALLATION & OPERATING INSTRUCTIONS MANUAL

INSTALLER AND OWNER'S MANUAL

NT-20000 MODEL

2 POST LIFT
20 000 LB CAPACITY

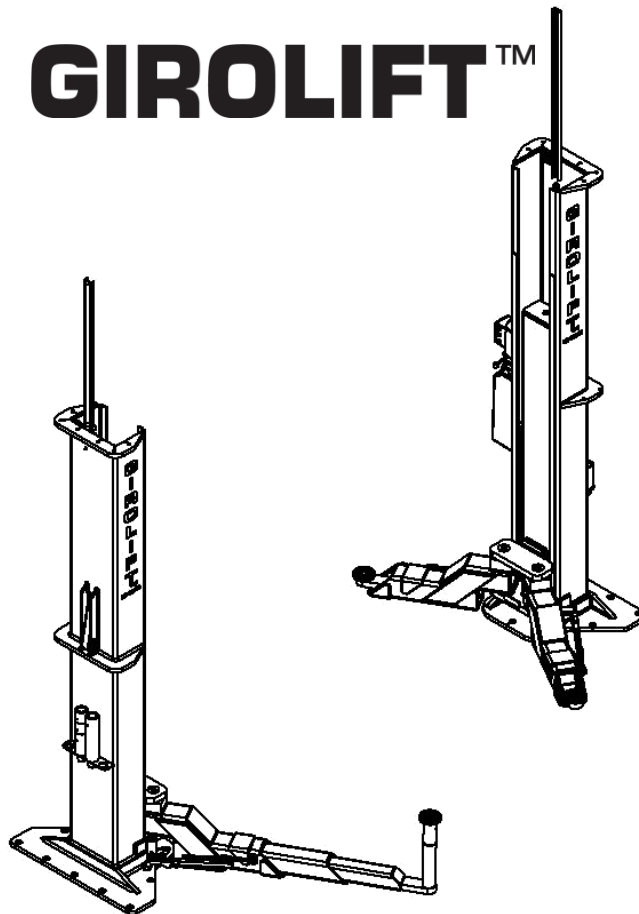

IMPORTANT SAFETY INSTRUCTIONS SAVE THESE INSTRUCTIONS

**READ THIS MANUAL CAREFULLY BEFORE INSTALLING, OPERATING, SERVICING OR
MAINTAINING THE LIFT.**

OPERATING CONDITION

THE LIFT IS DESIGNED FOR **INDOOR USE ONLY** AND OPERATING IN A DRY ENVIRONMENT FOR TEMPERATURE BETWEEN 5° TO 40°C (41° – 104°F).
LIFT'S INSTALLATION OUTSIDE IS PROHIBITED.

CANADA HYDRAULIQUE EQUIPEMENT INC. DISCLAIMS ALL LIABILITY IF THE CONDITIONS ARE NOT FULFILLED.

MANUAL : MAN-NT-20000-SYM-C01-E

N.B. CANADA HYDRAULIQUE EQUIPEMENT INC. IS CERTIFIED BY CWB (CANADIAN WELDING BUREAU) ACCORDING TO CSA W47.1 AND CSA W59 STANDARDS.

ASSISTANCE

(FOR PARTS¹, SERVICE OR TECHNICAL QUESTIONS)

(WRITE DOWN DISTRIBUTOR INFORMATION IN BOX)

HAVE MODEL AND SERIAL NUMBERS OF GIROLIFT ANS SERIAL NUMBER AND MODEL OF POWER UNIT FOR SERVICE AND PARTS :

GIROLIFT MODEL : _____

GIROLIFT SERIAL NUMBER : _____

POWER UNIT SERIAL NUMBER (" SERIAL NO. + DATE COTE " FOR S MODEL) : _____

POWER UNIT MODEL ("MODEL NUMBER") : _____

(INFORMATIONS IN HATCHED BOXES OF **FIGURES 1 AND 2.**)

GIROLIFT™

MODÈLE / MODEL

Q. SÉRIE / SERIAL #

DATE FAB. / MFG DATE

CAPACITÉ / CAPACITY PRESSION / PRESSURE

LB PSI

CANADA HYDRAULIQUE ÉQUIPEMENT INC.
2708 ROUTE 341 NORD, SAINT-JACQUES, CAN. (QC) J0K 2R0
1 450 839-6562
FABRIQUÉ AU CANADA / MADE IN CANADA

FIGURE 1 : NAMEPLATE ON MASTER COLUMN

CUSTOMER

SERIAL NO. PART NUMBER

DATE CODE MODEL NUMBER

COUNTRY OF ORIGIN

FACTORY WIRED AT AMPS AT MAX. WORKING LOAD RELIEF P.S.I.

STONE ROCKFORD, IL WWW.STONEHYDRAULICS.COM

S MODEL

FIGURE 2 : POWER UNIT LABEL

RHINO

| | | | |
|--------|-------------------------|-------|----------------------------|
| HP: | MODEL NO.: | VOLT: | VOLT: |
| HZ: | RPM : | KVA: | FLA: FLA: |
| PH: | NOT THERMALLY PROTECTED | | TOTAL ENCLOSED, NON-VENTED |
| FRAME: | DUTY: | | |
| TYPE: | MAX. AMB: | PRV: | |
| DATE: | INS CLASS: | CODE: | |

SERIAL NUMBER

R MODEL

MANUFACTURER

CANADA HYDRAULIQUE EQUIPEMENT INC.

450-839-6562
1-888-839-6562
(TOLL-FREE NUMBER)

450-839-9072
 INFO@GIROLIFT.COM

WWW.GIROLIFT.COM

WORKING TIME (EASTERN TIME)

MONDAY TO THURSDAY 8:00 TO 17:00
FRIDAY 8:00 TO 12:00
SATURDAY AND SUNDAY CLOSED

¹ PARTS AVAILABLE ONLINE : WWW.GIROLIFT.COM/EN/ACCESSORIES

TABLE OF CONTENTS

ASSISTANCE 2

TABLE OF CONTENTS 3

GENERAL SPECIFICATIONS 4

MAIN COMPONENT IDENTIFICATION 6

LIST OF RECOMMENDED TOOLS FOR INSTALLATION 6

LIST OF MATERIALS PROVIDED 7

INSTALLATION INSTRUCTIONS 8

 COLUMN INSTALLATION 8

 POWER UNIT INSTALLATION 11

 PNEUMATIC AND HYDRAULIC LINE INSTALLATION 13

 OPERATING TESTS 15

 ▪ *TO BLEED AIR OF HYDRAULIC CONDUITS* 15

 ▪ *TEST UNDER PRESSURE* 16

 ▪ *SWING ARMS LEVELLING* 17

 ▪ *OPERATING TEST WITH A TYPICAL VEHICLE* 18

OPERATING INSTRUCTIONS 19

 OWNER / EMPLOYER RESPONSIBILITY 19

 IMPORTANT SAFETY INSTRUCTIONS 19

 LIFT OPERATION 21

MAINTENANCE AND INSPECTION INSTRUCTIONS 23

 MAINTENANCE INSTRUCTIONS 23

 WORKSHOP BEST PRACTICES 23

 LIFT CLEANING 23

 ▪ *LIGHT CLEANING* 23

 ▪ *HEAVY-DUTY CLEANING* 23

 LIFT LUBRICATION 23

 ▪ *GENERAL LUBRICATION* 23

 ▪ *BASES OF THE CYLINDER AND BASES COLUMNS LUBRICATION* 23

 DAILY MAINTENANCE 24

 MONTHLY MAINTENANCE 24

 ANNUAL INSPECTION 25

 TROUBLESHOOTING 26

 LOCKOUT/TAGOUT 28

WARRANTY POLICY 29

PART LIST 30

 NT-20000-SYM-C01 GIROLIFT 30

 COLUMN 31

 LOAD HOLDER 31

 LIFTING ADAPTER 31

 CYLINDER 32

 AUTOMATIC SWING ARM RESTRAINT 32

 POWER UNIT 32

 LABEL 33

ANNEX 1 35

ANNEX 2 36

ANNEX 3 37

MAN-NT-20000-SYM-C01-E

GENERAL SPECIFICATIONS

| LIFT SPECIFICATIONS | VALUES |
|---------------------|---------------|
| PNEUMATIC PRESSURE | 80 TO 125 PSI |
| LIFTING HEIGHT | 72" |
| OPERATING PRESSURE | 3100 PSI |

| LIFT SPECIFICATIONS | VALUES |
|---|----------|
| TOTAL HEIGHT | 154-1/4" |
| APPROXIMATE SHIPPING WEIGHT (LIFT AND PACKAGING) | 4500 LB |

| POWER UNIT VOLTAGE* | MODEL | LIFTING SPEED | LOWERING SPEED | SPEED | POWER | AMPERAGE | DUTY CYCLE | |
|-----------------------|-------|---------------|----------------|---------|-------|----------|------------|---------|
| | | | | | | | ON | OFF |
| 220 V / 1 PH. / 60 HZ | R | 92 SEC | 24 SEC | 2 GMP | 2 HP | 15 A | 93 SEC | 507 SEC |
| 575 V / 3 PH. / 60 HZ | S | 105 SEC | 24 SEC | 1.8 GMP | 2 HP | 5 A | 120 SEC | 600 SEC |

***NOTE :** USE TIME DELAY FUSE WITH THIS LIFT.

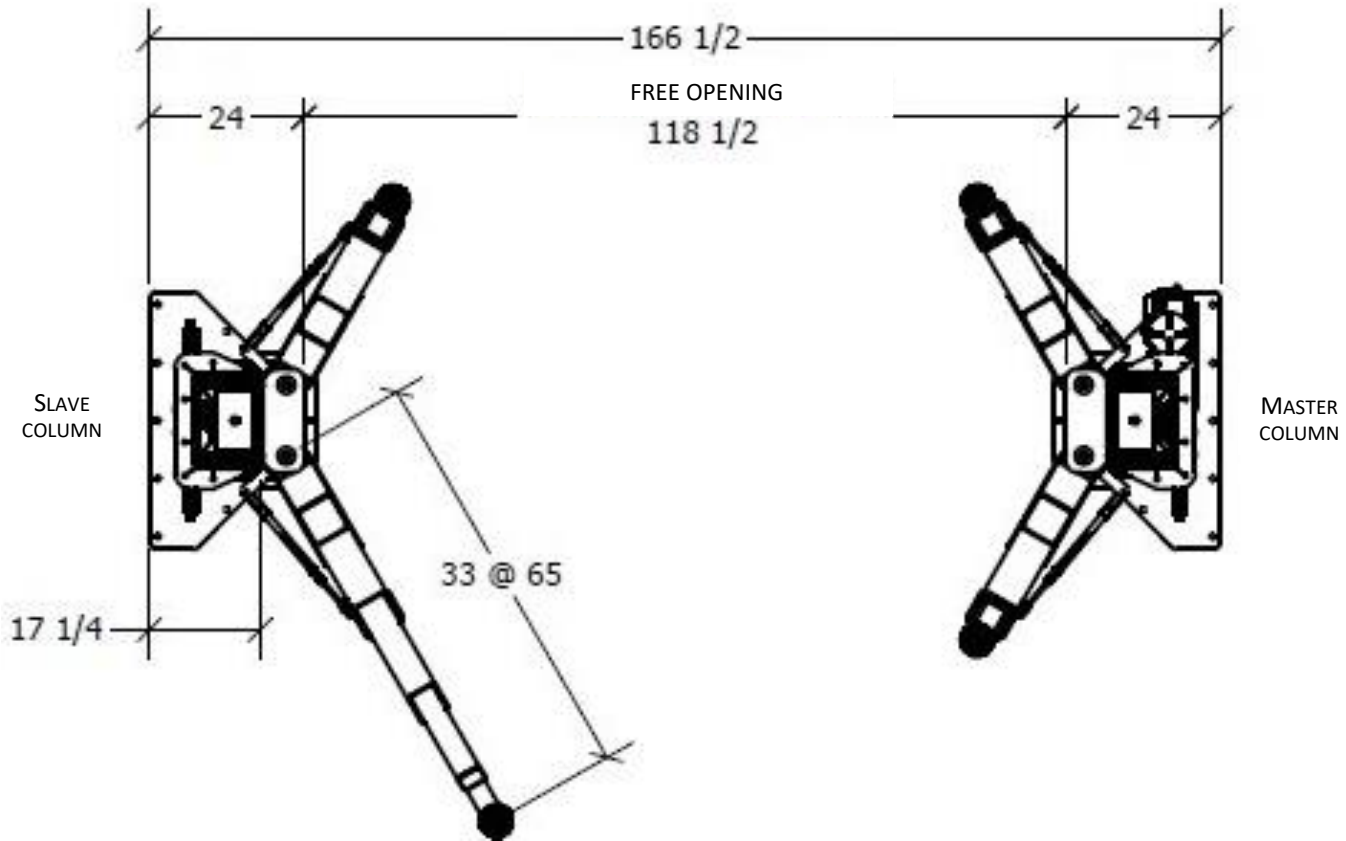

FIGURE 3 : LIFT TOP VIEW

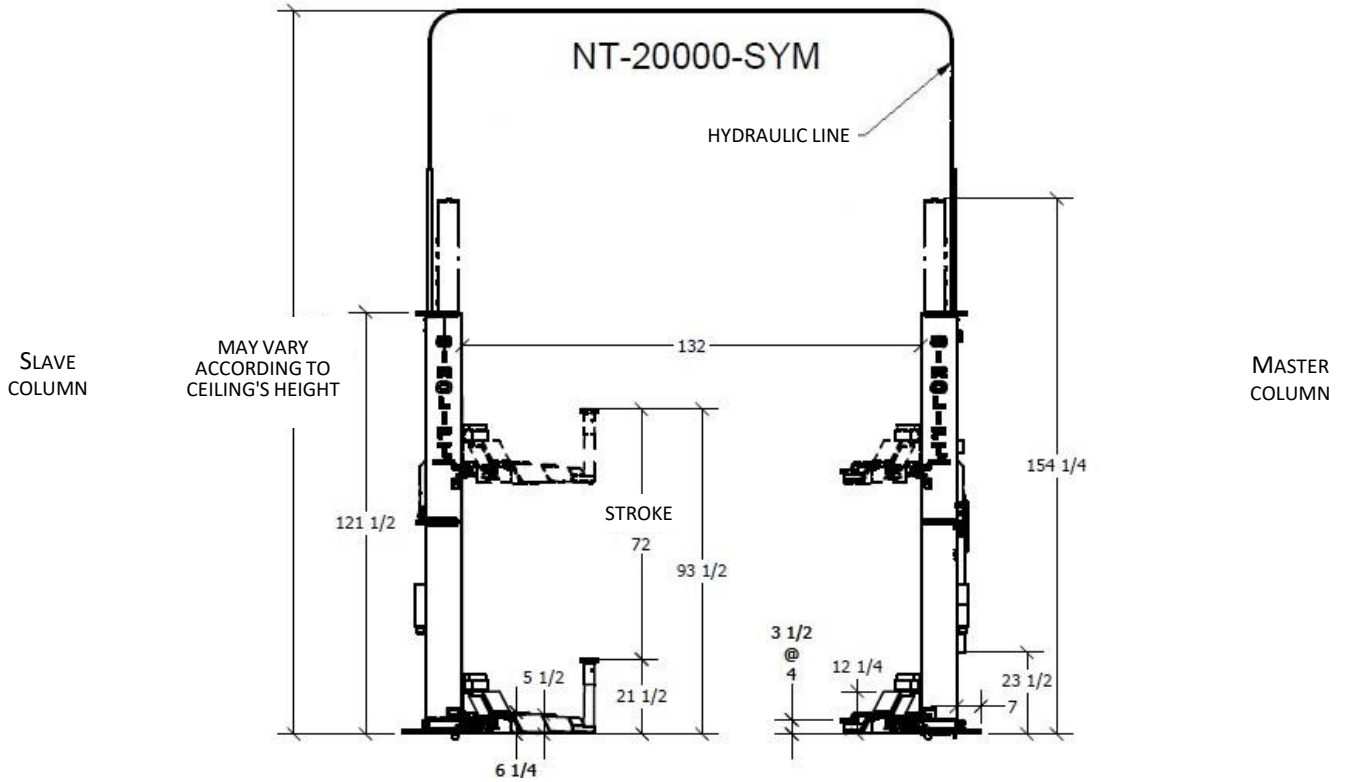

FIGURE 4: LIFT SIDE VIEW

NOTE : THE DIMENSIONS ARE CALCULATED FROM THE BASE ON THE GROUND AND LEVELLED (WITH SHIMS).

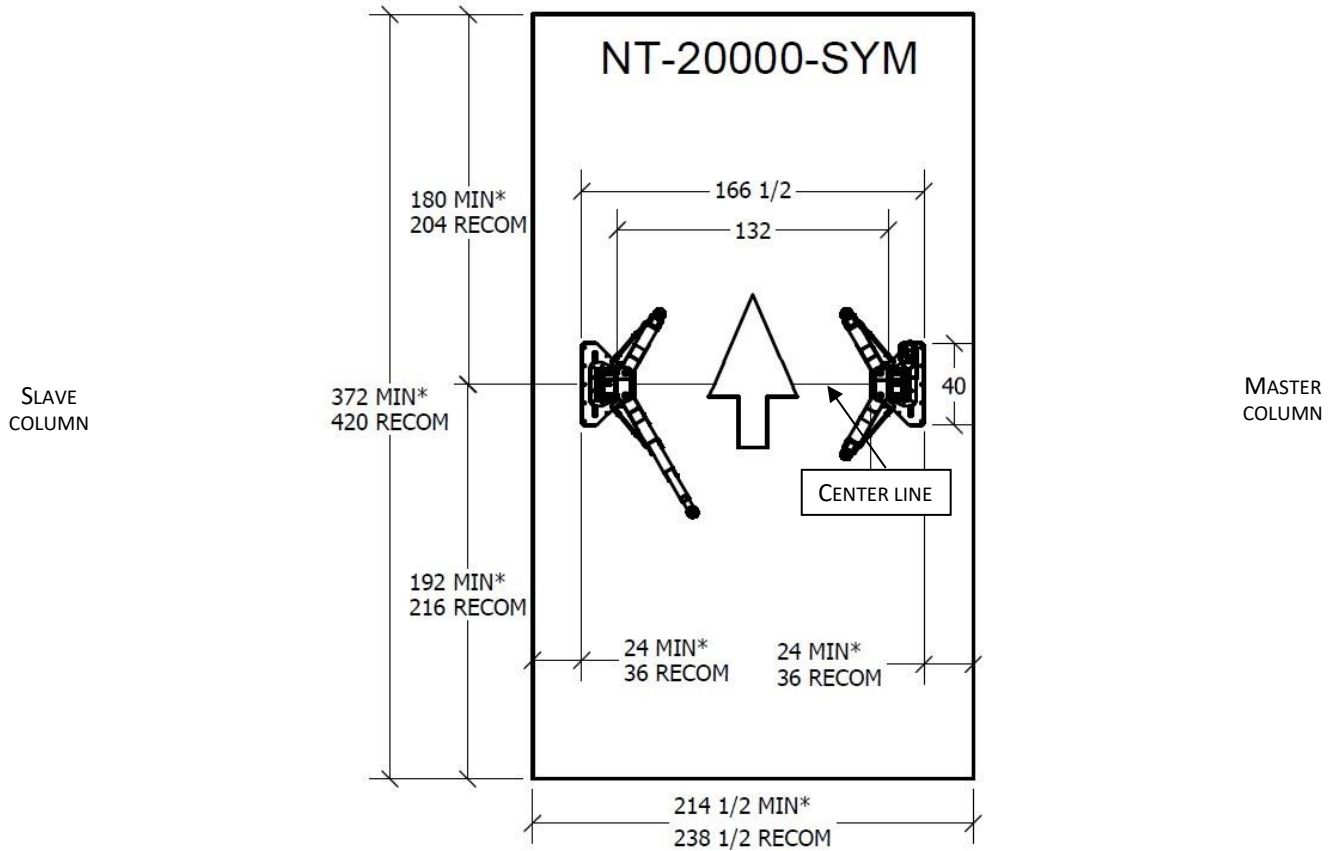

FIGURE 5 : MINIMUM AND RECOMMENDED BAY DIMENSIONS

MAIN COMPONENT IDENTIFICATION

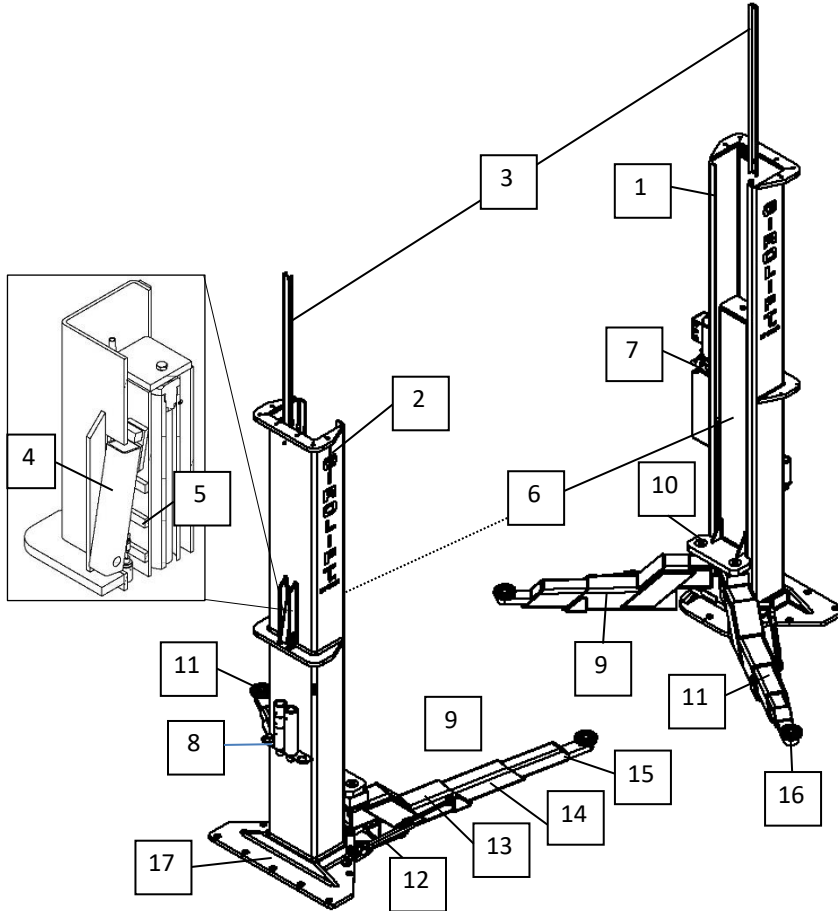

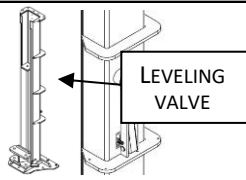
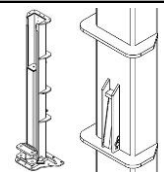

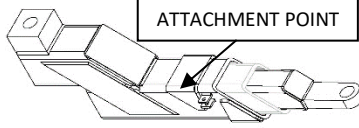
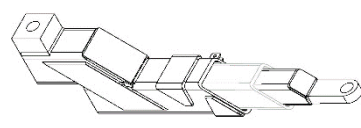

FIGURE 6 : MAIN COMPONENT IDENTIFICATION

| # | IDENTIFIED COMPONENTS |
|----|--|
| 1 | MASTER COLUMN (WITH POWER UNIT) |
| 2 | SLAVE COLUMN |
| 3 | CHANNEL |
| 4 | LOAD HOLDER |
| 5 | STOP BLOCK |
| 6 | CARRIAGE |
| 7 | POWER UNIT |
| 8 | EXTENSION SOCKET SUPPORT AND EXTENSION SOCKETS |
| 9 | LEFT SWING ARM |
| 10 | SWING ARM PIN |
| 11 | RIGHT SWING ARM |
| 12 | AUTOMATIC SWING ARM RESTRAINT |
| 13 | FEMALE PART OF SWING ARM |
| 14 | CENTER PART OF SWING ARM |
| 15 | MALE PART OF SWING ARM |
| 16 | LIFTING PAD |
| 17 | BASE |

LIST OF RECOMMENDED TOOLS FOR INSTALLATION

| # | TOOLS | USE | # | TOOLS | USE |
|----|--|---|----|---|---|
| 1 | MEASURING TAPE - 50' LG | IF NEEDED | 12 | TUBE BENDER | TO FOLD DOM TUBES |
| 2 | CHALK MARKER | FLOOR INDICATIONS OF INSTALLATION SITE | 13 | TUBE CUTTER | TO CUT DOM TUBES |
| 3 | STRAIT LINE CHALK REEL | | 14 | ELECTRICAL TAPE | ATTACH PNEUMATIC TUBES |
| 4 | PERMANENT MARKER | | 15 | ADJUSTABLE WRENCH | IF NEEDED |
| 5 | SCREWDRIVER HANDLE PRY BAR | MOVE BASES OF COLUMNS AND INSTALL THE SHIMS | 16 | WRENCH SET 9/16"(2x), 3/4", 13/16", 7/8", 11/16" | IF NEEDED |
| 6 | HAMMER DRILL WITH CONCRETE HAMMER DRILL BIT 3/4" | DRILLING THE ANCHOR HOLES | 17 | STEPLADDER | INSTALL HYDRAULIC / PNEUMATIC CONDUITS |
| 7 | WET DRY VACUUM | CLEAN THE ANCHOR HOLES | 18 | RETRACTABLE BLADE KNIFE | CUT PNEUMATIC TUBE |
| 8 | HAMMER | DRIVE IN ANCHORS AND FIXATION OF DOM TUBES. | 19 | FLAT SCREWDRIVER 3/16" | TO BLEED THE AIR FROM THE HYDRAULIC SYSTEM |
| 9 | TORQUE WRENCH 1-1/8"-DRIVE | TIGHTEN ANCHORS | 20 | RAG | |
| 10 | TORQUE WRENCH 7/8"-DRIVE | TIGHTEN FITTINGS | 21 | TEFLON TAPE | CONNECT TO MAIN AIR INPUT |
| 11 | FUNNEL | FILL POWER UNIT TANK | 22 | PLIERS | LOCK THE CUTTER PINS OF THE AUTOMATIC SWING ARM RESTRAINT |

LIST OF MATERIALS PROVIDED

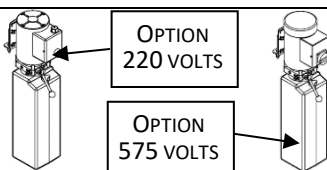
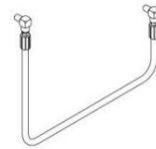
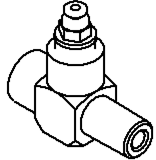
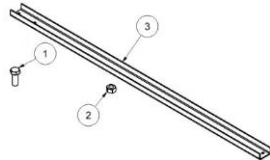
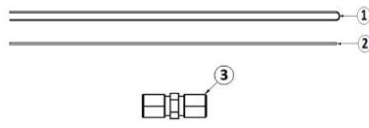
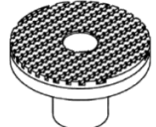
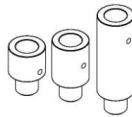
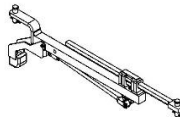
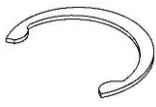
| QTY | ILLUSTRATION | QTY | ILLUSTRATION | QTY | ILLUSTRATION |
|---|---|-----|--|-----|--|
| 1 |  <p>MASTER COLUMN</p> <p>LEVELING VALVE</p> <p><i>NOTE: THE LEVELLING VALVE IS LOCATED ONTO THE MASTER COLUMN.</i></p> | 1 |  <p>SLAVE COLUMN</p> | 1 |  <p>WEDGE ANCHORS AND SHIMS KIT (STEEL)</p> <p>32 x 1/16 X 1-1/2 X 2-1/2" SHIM 10 x 1/8 X 1-1/2 X 2-1/2" SHIM 8 x 1/4 X 1-1/2 X 2-1/2" SHIM 4 x 3/8 X 1-1/2 X 2-1/2" SHIM 2 x 1/2 X 1-1/2 X 2-1/2" SHIM 16 x 3/4 X 7" ANCHORS, NUT AND WASHER</p> |
| 2 |  <p>LEFT SWING ARM</p> <p>ATTACHMENT POINT</p> | 2 |  <p>RIGHT SWING ARM</p> | 4 |  <p>SWING ARM PIN</p> |
| <p><i>NOTE: THE LOCATION OF THE ATTACHMENT POINT DIFFERS FROM LEFT AND RIGHT SWING ARM.</i></p> | | | | | |
| 1 |  <p>POWER UNIT</p> <p>OPTION 220 VOLTS OPTION 575 VOLTS</p> <p>2 x 3/8" NC NUT 2 x 3/8" x 1-3/4" BOLT</p> | 1 |  <p>HOSE ASSEMBLY Ø3/8" X 38" LG</p> | 1 |  <p>AIR LINE CONNECTION "TEE INLET" Ø 1/8</p> |
| 2 |  <p>SUPPORT BRACKET FOR HYDRAULIC LINE</p> <p>4 x BOLT 3/8" x 1" ZINC GR 5 (# 1) 4 x NUT 3/8" ZINC (# 2) 2 x CHANNEL 2" x 1" x 47" (# 3) 2 x TIE WRAP 5.6" LG.</p> | 1 |  <p>HYDRAULIC AND PNEUMATIC LINE</p> <p>1 x CLEAR POLYURETHANE TUBING 1/8" X 65' LG (# 1) 3 x TUBE DOM 5/8" x 0.065 x 120" LG (# 2) 2 x HYDRAULIC UNION – TUBE 5/8" X TUBE 5/8" (# 3)</p> | 4 |  <p>ROUND AND GROOVED LIFTING PAD 5000 LB CAPACITY</p> |
| 8 |  <p>EXTENSION SOCKET</p> <p>4 x Ø 3" X 3" LG / PIN – 2" LG SOCKET 2 x Ø 3" X 6" LG - PIN 2" LG SOCKET 2 x Ø 3" X 12" LG - PIN 2" LG SOCKET</p> | 4 |  <p>AUTOMATIC SWING ARM RESTRAINT</p> <p>8 x AXE CHAPE 8 x CUTTER PIN</p> | 4 |  <p>SNAP RING</p> |

INSTALLATION INSTRUCTIONS

REFER TO : ANSI/ALI ALIS :STANDARD FOR AUTOMOTIVE LIFTS - SAFETY REQUIREMENTS FOR INSTALLATION AND SERVICE

| | |
|------------------|---|
| ⚠ CAUTION | BEFORE INSTALLATION, REVIEW LOCAL CODES AND OBTAIN APPROPRIATE PERMITS(S) IF REQUIRED. |
| | CONSULT A QUALIFIED PERSON TO ADDRESS SEISMIC LOADS AND OTHER LOCAL AND STATE REQUIREMENTS. |
| | IF FLOOR SPECIFICATIONS AND RECOMMENDED MEASURES FOR THE LIFT CANNOT MEET THE REQUIREMENTS, CONTACT THE GIROLIFT MANUFACTURER BEFORE PROCEEDING TO THE INSTALLATION. |

COLUMN INSTALLATION

1. **FLOOR SPECIFICATIONS:** VERIFY AND MEET FLOOR SPECIFICATIONS BEFORE INSTALLATION. SEE **FIGURE 7.**

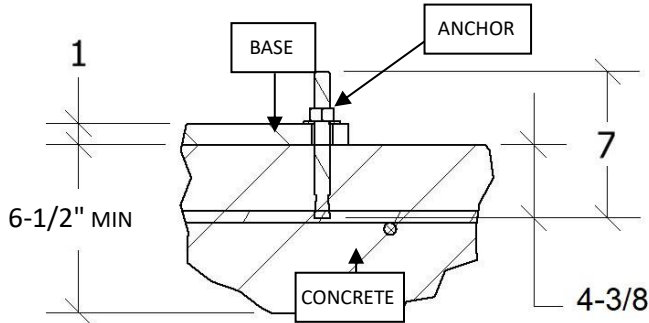

FIGURE 7 : CONCRETE BASE

| FLOOR SPECIFICATIONS | VALUES |
|----------------------|--|
| CONCRETE THICKNESS | 6-1/2" MINIMUM |
| COMPOSITION | CONCRETE WITH REINFORCEMENT |
| CAPACITY | SURFACE CONSTRAINT TO 4000 PSI (30MPA) |
| QUALITY | ANCHOR LOCATED AT MORE THAN 12" FROM CRACK OR FISSURE. |

| | |
|------------------|---|
| ⚠ WARNING | 1. DO NOT INSTALL THE LIFT ON ASPHALT OR ANY SIMILAR OR UNSTABLE COMPOUND. |
| | 2. DO NOT INSTALL THE LIFT IN A PIT OR DEPRESSION DUE TO FIRE OR EXPLOSION RISKS. |

2. **LOCATION OF THE GIROLIFT :** ACCORDING TO THE RECOMMENDED MEASURES OF **FIGURE 5**, MARK ON THE FLOOR THE GIROLIFT INSTALLATION SITE AND THE CENTER LINE.
- THE MINIMUM HEIGHT OF THE CEILING OR ANY OTHER STRUCTURE MUST BE AT MORE THAN 154-1/4" FROM THE GROUND. (RECOMMENDED CLEARANCE ABOVE LIFT)

3. **COLUMN ERECTION :**

| | |
|------------------|---|
| ⚠ CAUTION | DO NOT USE CHAINS OR OTHER ABRASIVE MATERIAL DIRECTLY ON THE COLUMN SURFACE WHICH COULD DAMAGE THE PAINT WHILE MOVING THE LIFT. |
|------------------|---|

3.1 USING A SAFE AND ADEQUATE HANDLING EQUIPMENT AND A LIFTING STRAP, MOVE THE COLUMN AT THE NEAREST INSTALLATION SITE. PLACE THE LIFTING STRAP AT THE CENTER OF GRAVITY (EQUAL WEIGHT DISTRIBUTION) OF THE COLUMN. SEE **FIGURE 8.**

| | |
|------------------|-------------------|
| ⚠ CAUTION | |
| | RISKS OF CRUSHING |

3.2 LAY DOWN THE COLUMN TO THE GROUND.

3.3 MOVE THE LIFTING STRAP TO PIVOT POINT UNDER THE TIGHTENER. SEE **FIGURE 8.**

3.4 RISE COLUMN 1" ABOVE GROUND TO

ROTATE IT VERTICALLY.

3.5 LOWER THE BASE NEAREST TO THE GROUND.

3.6 PUSH ON THE BASES SO THE COLUMN IS PERPENDICULAR TO THE FLOOR WHILE LOWERING IT AT THE SAME TIME TO THE GROUND.

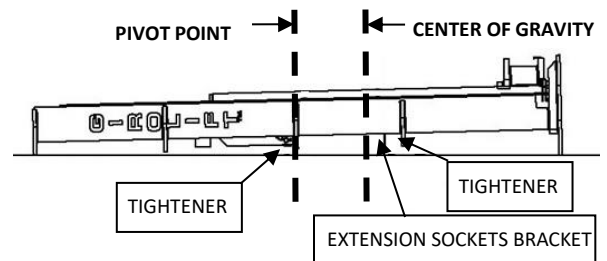

FIGURE 8 : POINT OF PIVOT AND CENTER OF GRAVITY OF A GROUND COLUMN

4. BASE ALIGNMENT ON THE SAME AXIS:

NOTE : IT IS STRONGLY RECOMMENDED TO INSTALL THE COLUMN AS SEEN OF **FIGURE 9** (MASTER COLUMN – VEHICLE PASSENGER SIDE) TO FACILITATE THE USER’S MOVEMENT WHILE USING THE LIFT. COLUMN INVERSION MAY BE MADE ACCORDING TO THE USER NEEDS.

4.1 INSERT 2 SCREWDRIVER HANDLE PRY BARS UNDER THE BASE WITH A MOVEMENT LEFT-RIGHT RIGHT-LEFT TO MOVE THE COLUMN. SEE **FIGURE 10**.

| | |
|--|--|
| <p>CAUTION</p> <p>RISKS OF CRUSHING</p> | <p>DO NOT PUT FINGERS UNDER THE SCREWDRIVER PRY BAR DURING THIS MANEUVER</p> |
|--|--|

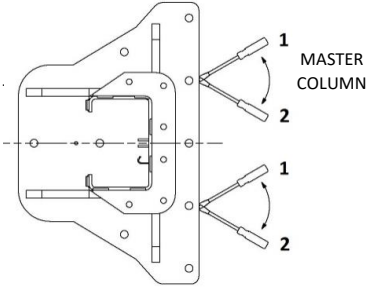
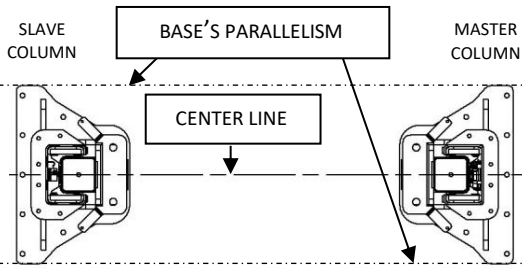

FIGURE 9 : ALIGNMENT ON THE SAME AXIS AND PARALLELISM

FIGURE 10 : MOVING METHOD OF COLUMNS.

4.2 VERIFY THE BASE’S ALIGNMENT ACCORDING TO THE CENTER LINE AND BASE’S PARALLELISM. SEE **FIGURE 9**.

5. ANCHOR INSTALLATION :

| STEP 1* | STEP 2 | |
|---|---|--|
| | | |
| <p>DRILL HOLES # 1 TO 7 ON THE 2 BASES TO A DEPTH OF 5-3/8" (INCLUDING BASE’S HEIGHT) USING A HAMMER DRILL WITH CONCRETE HAMMER DRILL BIT 3/4".</p> <p>NOTE: THE INDICATED DRILLING VALUES ARE THE MINIMUM VALUES TO BE RESPECTED IF THE CONCRETE THICKNESS IS 6-1/2". THE DRILLING MEASUREMENT MAY BE DEEPER IF THE CONCRETE THICKNESS IS MORE THAN 6-1/2".</p> | <p>ASPIRATE REMAINS WITH A WET DRY VACUUM INSIDE CAVITIES TO THE BOTTOM AND ON THE BASES.</p> | |

***NOTE :** HOLE #8 (NOT ACCESSIBLE AND DISSIMULATED UNDER THE SWING ARM BRACKET) WILL BE DRILLED AT OPERATION TEST – TEST UNDER PRESSURE.

| | |
|-----------------------|--|
| <p>CAUTION</p> | DO NOT DRILL THROUGH CONCRETE TO AVOID CRACKS IN THE CONCRETE FLOOR. |
|-----------------------|--|

| STEP 3 | STEP 4 | |
|--|--|---|
| | | |
| <p>ASSEMBLE THE ANCHORS : 3/4" NUT (#1), 3/4" WASHER (#2) AND 3/4 x 7" LG ANCHOR BOLT (#3). SCREW THE NUT EQUALITY WITH THE ANCHOR BOLT.**</p> | <p>INSERT THE 14 ANCHORS ASSEMBLED IN THE HOLES. WITH A HAMMER, INSERT THE ANCHORS ASSEMBLED TO THE BOTTOM.***</p> | <p>**NOTE : INSERT THE ANCHOR WITH A HAMMER; -SCREWING THE NUT HIGHER THAN THE END OF THE ANCHOR BOLT WILL DAMAGE THE NUT THREAD AND MAKE THE COMPONENT IRRETRIEVABLE. OR - SCREWING THE NUT LOWER THAN THE END OF THE ANCHOR BOLT WILL FOLD UP THE ANCHOR BOLT ON THE NUT AND WILL NO LONGER ALLOW THE EXIT OF THE NUT.</p> |

*****NOTE :** THE ANCHORS SHOULD COME OUT OF ≈1-5/8" FROM THE BASE IF CONCRETE HAS A MINIMUM THICKNESS OF 6-1/2". IN CASE OF CONCRETE THICKNESS BIGGER THAN 6-1/2", ANCHORS SHOULD COME OUT OF AT LEAST 1" FROM THE BASE IN ORDER TO SCREW THE NUTS ON THE ANCHOR BOLTS.

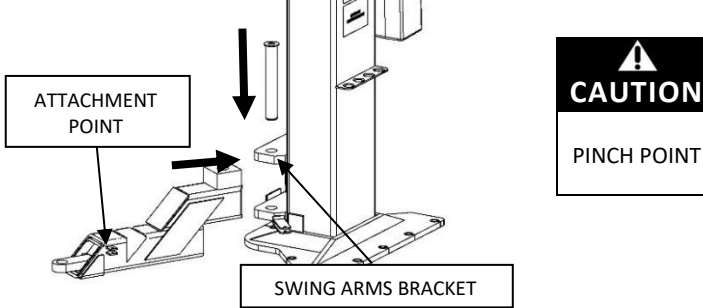
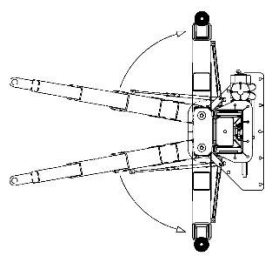
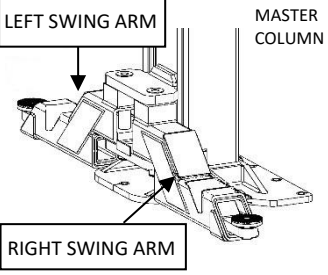

MAN-NT-20000-SYM-C01-E

6. SWING ARMS INSTALLATION :

| STEP 1 | STEP 2 | STEP 3 |
|--|--|---|
|  |  |  |
| <p>1. INSERT A SWING ARM INTO THE SWING ARM BRACKET.* 2. INSERT THE SWING ARM PIN. 3. REPEAT FOR THE 3 REMAINING SWING ARMS.</p> | <p>OPEN UP SWING ARMS</p> | <p>FINAL ASSEMBLY.</p> |

***NOTE :** ENSURE THAT THE ATTACHMENT POINTS OF THE SWING ARMS POINT TO THE OUTSIDE.

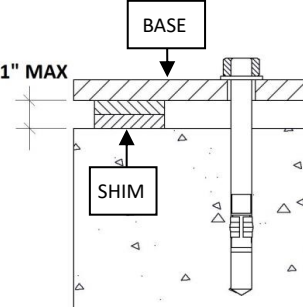
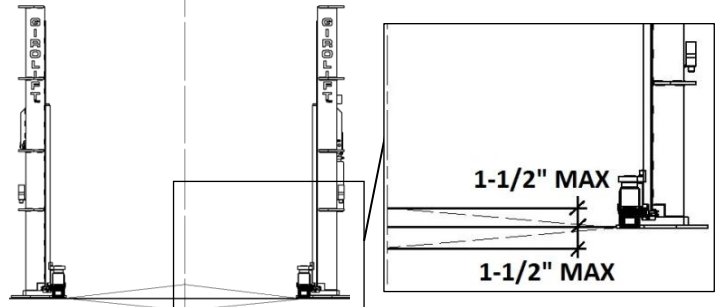
7. COLUMNS LEVELLING** :

| NOTICE 1 | NOTICE 2 | NOTICE 3 |
|--|---|--|
|  |  |  |
| <p>DO NOT EXCEED 1" OF SHIM THICKNESS.</p> | <p>THE FLOOR SLOPE MUST NOT EXCEED 1-1/2" HIGHER OR LOWER THAN THE FLOOR LEVEL.</p> | <p>USE ONLY THE STEEL SHIMS SUPPLIED BY THE MANUFACTURER.</p> |

****NOTE :** COLUMNS IN VERTICAL POSITION MAY NOT BE LEVEL BUT THEY MUST BE ALIGNED BETWEEN THEM AND FOLLOW THE FLOOR LEVEL.

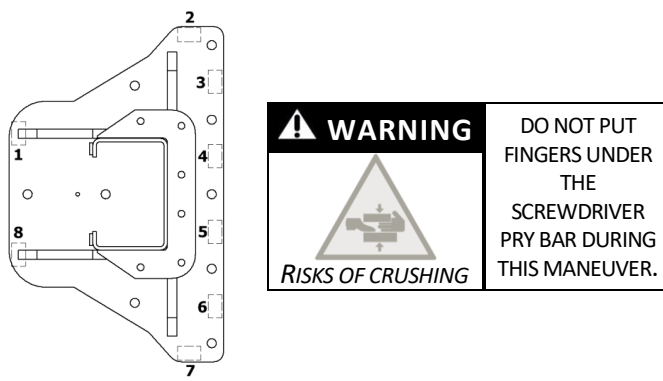
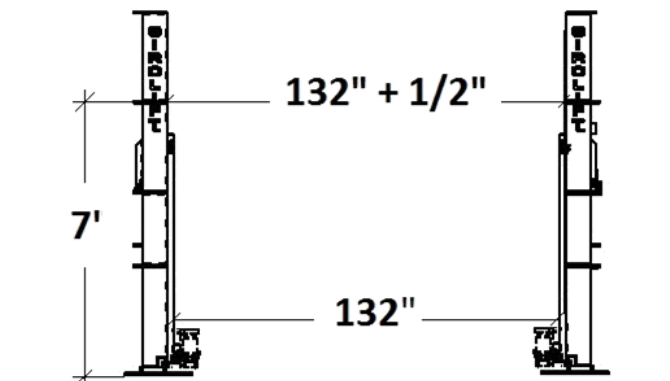
| STEP 1*** | STEP 2 |
|---|---|
|  |  |
| <p>WITH SCREWDRIVER PRY BARS, ADD SHIMS AT THE 8 DOTTED IDENTIFICATIONS AT EQUAL INTERVALS BETWEEN ANCHORS.</p> | <p>MEASURE OPENING BETWEEN COLUMNS : 1/2" (132-1/2") AT 7' HIGH. IF THE OPENING OF 1/2" AT 7' HIGH IS NOT FULFILLED, REMOVE SHIMS OR RETURN TO PREVIOUS STEP. (TOLERANCE 3/8" TO 1/2" AT 7' HIGH)</p> |

*****NOTE :** THE COLUMN BASE MUST NEVER BE IN DIRECT CONTACT WITH THE FLOOR. THE USE OF THE 8 DOTTED IDENTIFICATIONS IS REQUIRED.

MAN-NT-20000-SYM-C01-E

8. SWING ARMS LEVELLING :

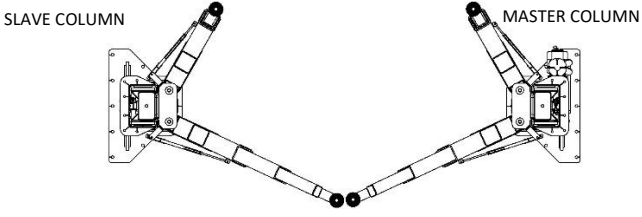
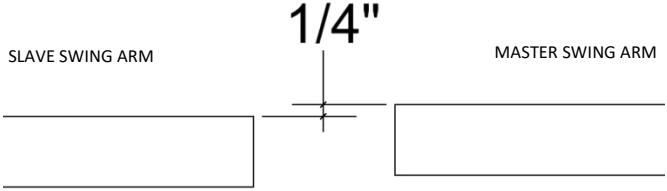
| STEP 1 | STEP 2 |
|--|---|
|  <p>SLAVE COLUMN MASTER COLUMN</p> |  <p>SLAVE SWING ARM 1/4" MASTER SWING ARM</p> |
| <p>STRETCH 2 OPPOSED SWING ARMS AS CLOSE AS POSSIBLE.</p> | <p>ADD OR REMOVE SHIMS AT DOTTED IDENTIFICATION OF STEP 1 – COLUMN LEVELLING SO THAT THE MASTER SWING ARM IS 1/4" HIGHER THAN THE SLAVE SWING ARM.</p> |

9. FINISHING ANCHOR INSTALLATION* :

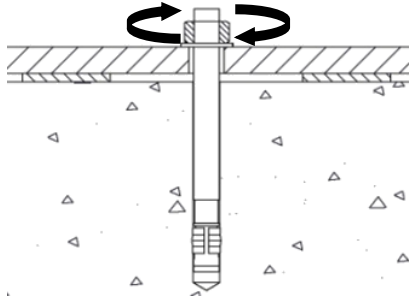
| STEP 1* |
|--|
|  |
| <p>SCREW 3/4" ANCHOR NUTS WITH A TORQUE WRENCH 1-1/8" – DRIVE AT 100 POUND-FOOT.</p> |

CAUTION DO NOT USE AN IMPACT WRENCH TO TIGHTEN NUTS. THE VIBRATION CAUSED BY THIS TOOL CAN REDUCE THE CAPACITY OR DAMAGE THE CONCRETE.

IMPORTANT* DO NOT USE FILLING MATERIAL OR GROUT UNDER BASES OF COLUMNS OR SEALED THE BASE TO THE FLOOR ; THIS ADDITION MAY RESTRICT THE DESIRABLE PTO FROM THE CONCRETE FLOOR AT LIFT RISE.

POWER UNIT INSTALLATION

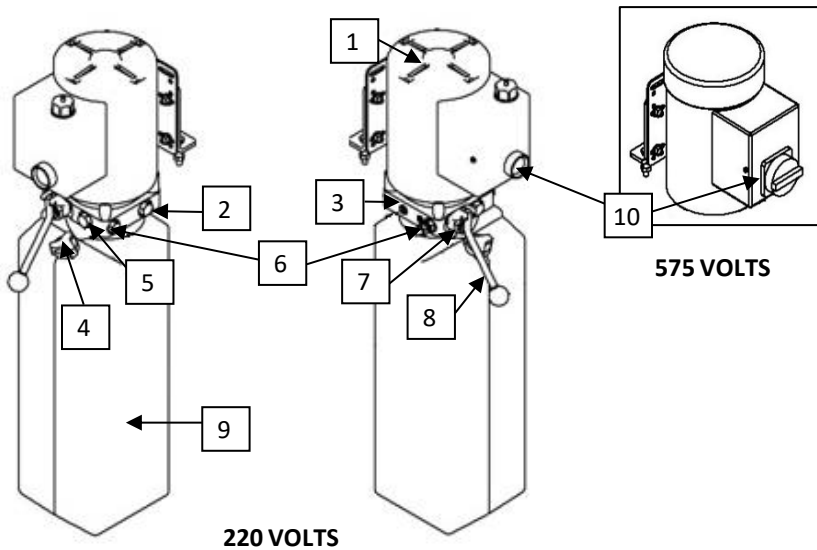

| # | ITEM |
|----|-------------------------|
| 1 | ELECTRIC MOTOR |
| 2 | RELIEF CARTRIDGE CAP* |
| 3 | TANK RETURN |
| 4 | HYDRAULIC VENT CAP |
| 5 | CHECK VALVE CARTRIDGE |
| 6 | HYDRAULIC INLET/OUTLET |
| 7 | RELEASE VALVE |
| 8 | PRESSURE RELEASE HANDLE |
| 9 | HYDRAULIC OIL TANK |
| 10 | ON/OFF SWITCH |

***NOTE :** A SAFETY SEAL IS APPLIED TO THIS COMPONENT. BREAKING THE SEAL VOIDS THE LIFT WARRANTY

FIGURE 10 : POWER UNIT COMPONENT IDENTIFICATION

MAN-NT-20000-SYM-C01-E

| MANUFACTURER INSTRUCTIONS | |
|---------------------------|--|
| 1 | USE GRADE 32 HYDRAULIC OIL. |
| 2 | INSTALL POWER UNIT AT LEAST 18" ABOVE GROUND. |
| 3 | IT IS THE ELECTRICIAN RESPONSIBILITY TO DETERMINATE THE AMPERAGE (A) OF THE POWER UNIT IN ACCORDANCE WITH "TIME DELAY" OR STANDARD OVERLOAD PROTECTION INSTALLED. |
| 4 | EACH GIROLIFT SHALL BE PROVIDED WITH AN INDEPENDENT CIRCUIT, INCLUDING OVERLOAD PROTECTION. OVERLOAD PROTECTION IS NOT SUPPLIED WITH THE GIROLIFT. THE CERTIFIED ELECTRICIAN IS REQUIRED TO CHOOSE THE APPROPRIATE DISCONNECT DEVICE. IF THE DISCONNECT DEVICE IS NOT INTEGRAL TO THE LIFT, THE GIROLIFT MUST BE EQUIPPED WITH AT LEAST ONE. |
| 5 | EACH DISCONNECT DEVICE SHALL PROVIDE FOR ISOLATION SAFETY REQUIREMENTS FOR LOCKOUT/TAGOUT OF ENERGY SOURCES. SEE SECTION MAINTENANCE AND INSPECTION INSTRUCTIONS – LOCKOUT/TAGOUT. |

| | |
|--|--|
|  WARNING | <p>" RISK OF EXPLOSION. THIS EQUIPMENT HAS INTERNAL ARCING AND SPARKING PARTS WHICH SHOULD NOT BE EXPOSED TO FLAMMABLE VAPORS. THIS EQUIPMENT IS ONLY SUITABLE FOR INSTALLATION IN A GARAGE HAVING SUFFICIENT AIR CIRCULATION TO BE CONSIDERED A NON-HAZARDOUS LOCATION. »</p> |
|--|--|

10. TANK FILLING : WITH A FUNNEL, FILL THE TANK UP TO 1" OF THE HYDRAULIC VENT CAP. FIRMLY CLOSE THE HYDRAULIC VENT CAP.

11. POWER UNIT INSTALLATION :

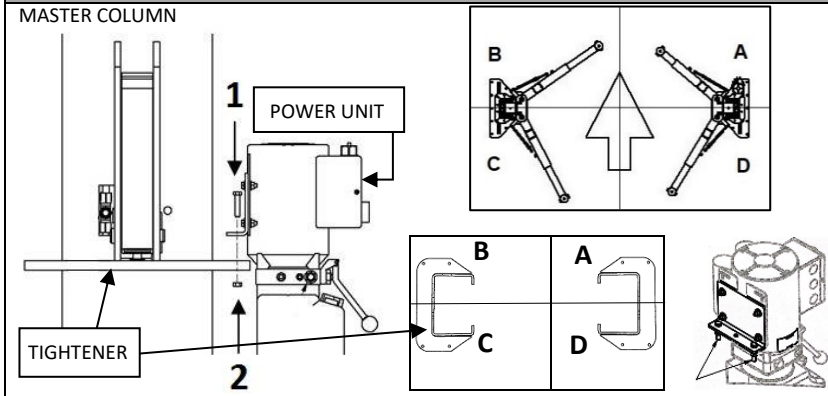
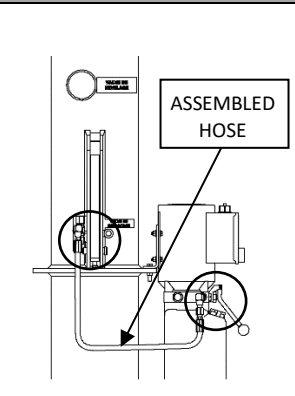
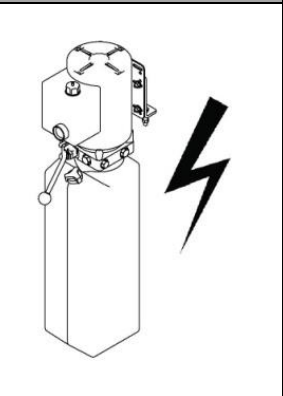
| STEP 1 | STEP 2* | STEP 3 |
|--|---|--|
|  <p>MASTER COLUMN</p> <p>POWER UNIT</p> <p>TIGHTENER</p> <p>DIAL A & C</p> <p>DIAL B & D</p> <p>ADAPTEUR</p> <p>BACK OF THE POWER UNIT WITH BRACKET VIEW</p> |  <p>ASSEMBLED HOSE</p> |  |
| <p>INSTALL THE POWER UNIT TO THE MASTER COLUMN TIGHTENER WITH 2 BOLTS (#1) AND 2 NUTS (#2). DIAL A IS RECOMMENDED, FOR ANY OTHER CHANGE, SETTLE THE ADAPTER POSITIONING, IF APPLICABLE.</p> | <p>CONNECT THE $\varnothing 3/8"$ x 38" LG ASSEMBLED HOSE TO THE POWER UNIT AND THE DEVICE ON THE MASTER COLUMN.</p> | <p>CONNECT THE POWER UNIT TO THE ELECTRIC PANEL BY A CERTIFIED ELECTRICIAN.</p> <p>NOTE: 575 V POWER UNIT WIRING MUST BE DONE COUNTERCLOCKWISE.</p> |

***NOTE :** DO NOT PUT ON TEFLON TAPE AT THE ENDS OF THE $\varnothing 3/8"$ x 38" ASSEMBLED HOSE.

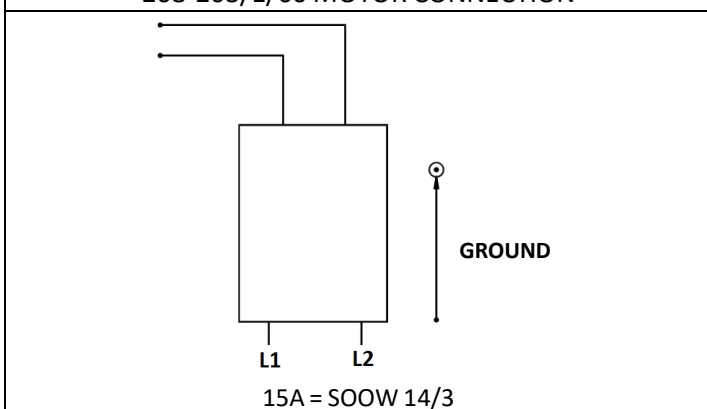
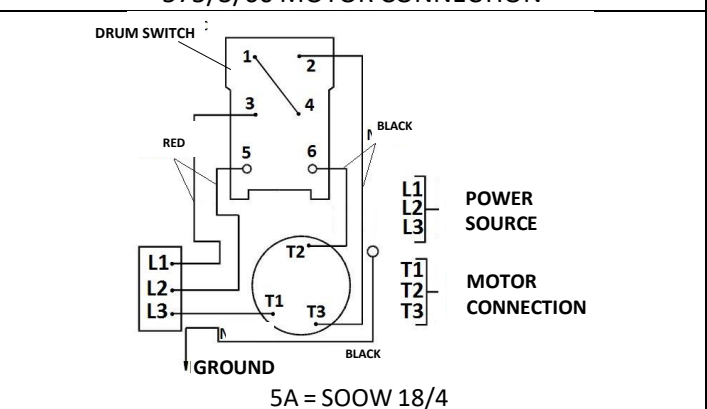
| 208-203/1/60 MOTOR CONNECTION | 575/3/60 MOTOR CONNECTION |
|---|--|
|  <p>L1 L2</p> <p>GROUND</p> <p>15A = SOOW 14/3</p> |  <p>DRUM SWITCH</p> <p>RED BLACK</p> <p>L1 L2 L3 POWER SOURCE</p> <p>T1 T2 T3 MOTOR CONNECTION</p> <p>GROUND BLACK</p> <p>5A = SOOW 18/4</p> |

PNEUMATIC AND HYDRAULIC LINE INSTALLATION

12. PNEUMATIC AND HYDRAULIC LINE INSTALLATION:

| | | |
|--|---|--|
| <p>FINAL ASSEMBLY</p> <p>WALL</p> <p>MAIN AIR INPUT</p> | <p>STEP 1</p> <p>LEVELLING VALVE</p> <p>PRESSURE RELEASE HANDLE</p> <p>ON THE MASTER COLUMN, OPEN THE LEVELLING VALVE. PUSH DOWN PRESSURE RELEASE HANDLE TO RELEASE ANY PRESSURE FROM THE HYDRAULIC SYSTEM. CLOSE THE LEVELLING VALVE.</p> | <p>STEP 2*</p> <p>PREASSEMBLY AREA</p> <p>REMOVE THE ORANGE SAFETY PLUGS IN THE HYDRAULIC UNIONS OF THE 2 PREASSEMBLY AREAS LOCATED AT THE TOP OF THE COLUMNS AND AT THE ENDS OF THE 3 TUBES DOM.</p> |
|--|---|--|

*** CAUTION** NON-REMOVAL OF THE ORANGE SAFETY PLUGS MAY CAUSE PARTIAL OR COMPLETE OBSTRUCTION OF THE HYDRAULIC LINE AT THE RISE. THE OBSTRUCTED PART OF THE HYDRAULIC LINE WILL NEED TO BE CLEANED OR REPLACED.

| | | |
|--|---|--|
| <p>STEP 3</p> <p>REMAINING UNION</p> <p>COMPRESSION SLEEVE</p> <p>NUT</p> <p>ASSEMBLED TUBE DOM WITH HYDRAULIC UNION</p> | <p>STEP 4</p> <p>15"</p> | <p>STEP 5</p> <p>152"</p> <p>HEIGHT</p> <p>121-1/2"</p> <p>6"</p> <p>Y</p> |
| <p>WITH A TORQUE WRENCH (42 LB-FT), SCREW A HYDRAULIC UNION TO THE END OF 2 TUBES DOM (WITHOUT A PNEUMATIC TUBE) ; ONLY THE PART OF THE UNION WHERE THE TUBE ENTERS MUST BE TIGHTENED. NOTE : ENSURE THAT THE TUBE MEETS THE UNION BEFORE TIGHTENING.</p> | <p>WITH A PIPE BENDER, BEND TO 90° THE 2 ASSEMBLED TUBES DOM (WITHOUT PNEUMATIC TUBES) AT 15" FROM THE HYDRAULIC UNION.</p> | <p>DETERMINE THE HEIGHT OF LATERAL TUBES DOM (Y VALUE) :</p> <p>HEIGHT – 115-1/2" = Y</p> <p>HEIGHT = CLEARANCE HEIGHT ABOVE GROUND OR ANY OTHER INTERFERENCE (HEATING SYSTEM, GARAGE DOOR, ETC.) NOTE : MINIMUM CLEARANCE HEIGHT IS 180" ABOVE GROUND.</p> |

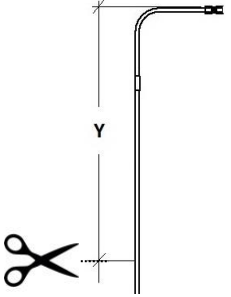
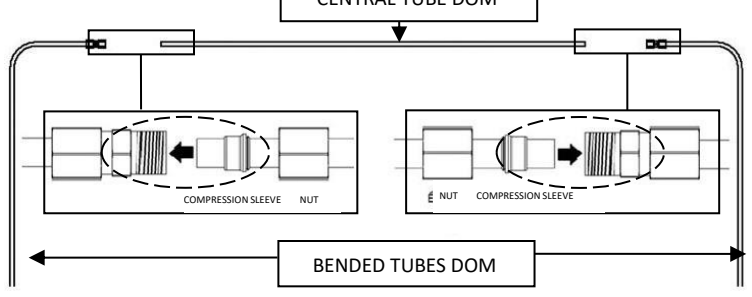
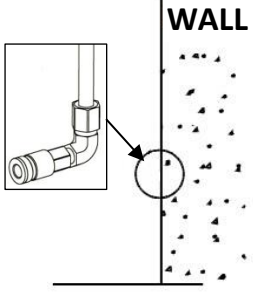
| STEP 6* | STEP 7 | STEP 8 |
|---|--|--|
|  |  |  |
| <p>CUT TUBE DOM EXCEEDING WITH PIPE CUTTER, DEBURRING WITH SANDING PAPER AND REMOVE ALL REMAINS INSIDE AND ON THE TUBE DOM.</p> | <p>COAT OF HYDRAULIC OIL THE HYDRAULIC UNION THREADS AND THE COMPRESSION SLEEVE. (DOTTED PARTS IDENTIFIED) WITH A TORQUE WRENCH (42 LB-FT), ASSEMBLE 2 BENDED TUBES DOM WITH THE CENTRAL TUBE DOM CENTRAL BY SCREWING THE HYDRAULIC UNION. NOTE : ENSURE THAT THE TUBE MEETS THE UNION BEFORE TIGHTENING.</p> | <p>IDENTIFY THE MAIN AIR INLET. NOTE : THE MAIN AIR INLET MUST BE LOCATED WITHIN 25' FROM THE MASTER COLUMN.</p> |

*NOTE : OPTIONAL STEP IF THE CLEARANCE HEIGHT IS MORE THAN 216" ABOVE THE GROUND.

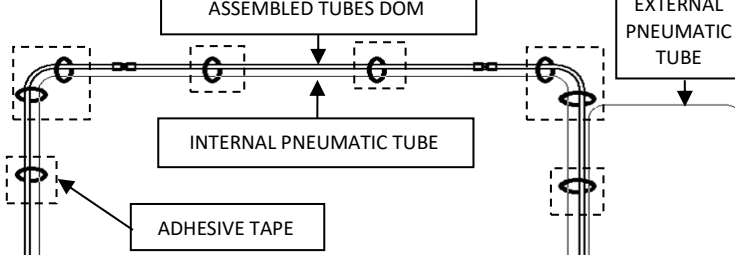
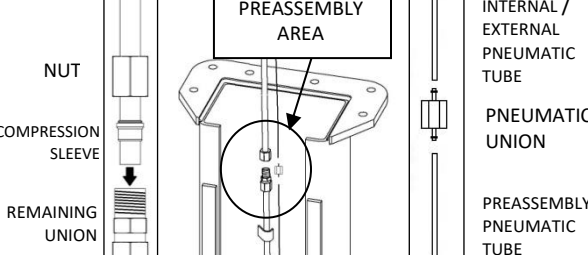
| STEP 9 | STEP 10 |
|---|--|
|  |  |
| <p>ATTACHED PNEUMATIC TUBES TO ASSEMBLED TUBES DOM** :</p> <ol style="list-style-type: none"> TEND AND ATTACH THE INTERNAL PNEUMATIC TUBE (FIXED PARTIALLY TO THE CENTRAL TUBE DOM) ON THE FULL LENGTH OF THE ASSEMBLED TUBE DOM WITH ADHESIVE TAPE (I.E. ELECTRICAL TAPE). ACCORDING TO THE MAIN AIR INLET (STEP 8), ATTACHED THE 65' EXTERNAL PNEUMATIC TUBE TO THE ASSEMBLED TUBES DOM WITH ADHESIVE TAPE TO MAKE THE SHORTEST DISTANCE BETWEEN THE AIR INLET AND THE PREASSEMBLY LOCATED INSIDE THE MASTER COLUMN. <p>AIDE MEMOIRS : DO A KNOT AT THE END OF THE EXTERNAL PNEUMATIC TUBE THAT WILL BE FIXED IN THE PREASSEMBLY AREA OF THE MASTER COLUMN TO DISSOCIATE FROM THE INTERNAL PNEUMATIC TUBE. NOTE : DO NOT COMPRESS PNEUMATIC TUBES WITH ADHESIVE TAPE.</p> | <ol style="list-style-type: none"> INSERT THE END OF THE ASSEMBLED TUBE DOM IN THE PREASSEMBLY AREA AT EACH COLUMN AND SCREW EACH HYDRAULIC UNION WITH A TORQUE WRENCH (42 LB-FT). NOTE : ENSURE THAT THE TUBE MEETS THE UNION BEFORE TIGHTENING. CUT PNEUMATIC TUBE EXCEEDING; CONNECT WITH A PNEUMATIC UNION THE INTERNAL AND EXTERNAL PNEUMATIC TUBE WITH THE IDENTIFIED AND CORRESPONDING PNEUMATIC TUBE LOCATED IN THE PREASSEMBLY AREA OF EACH COLUMN. |

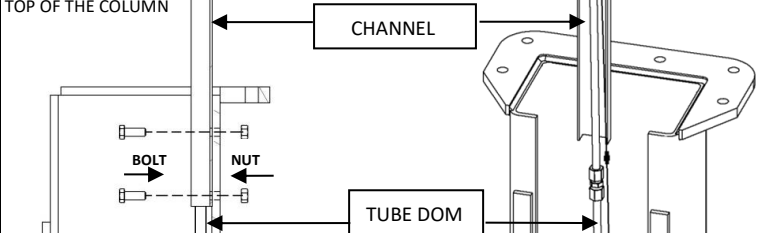
| STEP 11 | |
|---|--|
|  | <p>ATTACH A CHANNEL TO THE TOP OF EACH COLUMN WITH 2 NUTS AND 2 BOLTS.</p> |

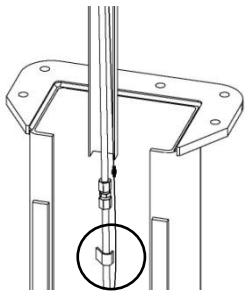
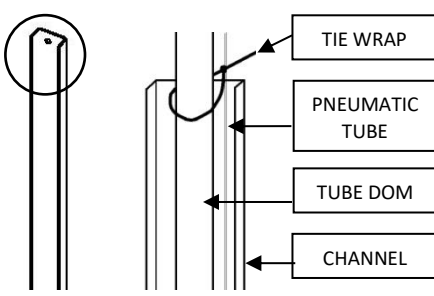
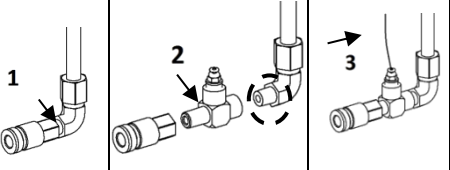
| STEP 12 | STEP 13 | STEP 14* |
|--|---|--|
|  |  <p>TIE WRAP PNEUMATIC TUBE TUBE DOM CHANNEL</p> |  <p>1 2 3</p> <p>LEGEND 1. MAIN AIR INLET 2. AIR LINE CONNEXION 3. EXTERNAL PNEUMATIC TUBE</p> |
| <p>WITH A HAMMER, LOCK THE HOOK ON THE TUBE DOM ONLY. NOTE : DO NOT LOCK THE HOOK ON THE PNEUMATIC TUBES.</p> | <p>ATTACH TUBES DOM TO THE TOP OF EACH CHANNEL OF EACH COLUMN WITH A PLASTIC TIE WRAP. NOTE : DO NOT FASTEN PLASTIC TIE WRAP ON PNEUMATIC TUBES.</p> | <p>TURN OFF THE PNEUMATIC POWER SUPPLY FROM THE MAIN AIR INLET. CONNECT EXTERNAL PNEUMATIC TUBE TO THE MAIN AIR INLET. ADD TEFLON TAPE TO THE PART IN DOTTED. NOTE : CONNECT THE EXTERNAL PNEUMATIC TUBE TO A DISTINCTIVE AIR INLET FOR THE PNEUMATIC POWER SUPPLY FOR EACH LIFT.</p> |

***NOTE :** IT IS THE OWNER'S RESPONSIBILITY TO HAVE A FUNCTIONAL AND ADEQUATE AIR INLET; EACH AIR INLET MUST HAVE A FILTER DRYER TO PROVIDE DRY AND CLEAN AIR TO EACH LIFT.

13. INSTALLATION FINISHING :

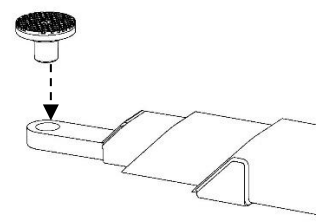
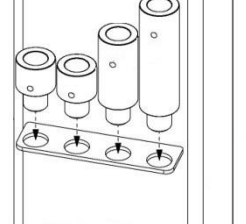
| STEP 1 | STEP 2 |
|--|--|
|  |  |
| <p>INSTALL LIFTING PADS IN HOLES AT THE END OF SWING ARMS.</p> | <p>INSTALL THE EXTENSION SOCKETS ON THE EXTENSION SOCKETS BRACKET.</p> |

OPERATING TESTS

TO BLEED AIR OF HYDRAULIC CONDUITS

1. VERIFY THAT THE LEVELLING VALVE IS CLOSED.
2. ACTIVATE THE HYDRAULIC UNIT TO RISE THE LIFTING ARMS APPROXIMATELY 4" ABOVE THE GROUND, THEN RELEASE.

NOTE : THE MASTER SWING ARMS WILL LIFT BEFORE THE SLAVE SIDE.

3. AT THE BOTTOM OF THE SLAVE COLUMN : WITH A FLAT SCREWDRIVER, UNSCREW (COUNTERCLOCKWISE) OF 1/2 TURN THE AIR BLEEDER. SEE **FIGURE 12**.

NOTE : TO LIMIT THE DAMAGE, PLACE RAGS ON THE SLAVE BASE UNDER THE AIR BLEEDER.

4. ON THE MASTER COLUMN, FULLY OPEN THE LEVELLING VALVE.
5. PUSH DOWN PRESSURE RELEASE HANDLE OF THE HYDRAULIC UNIT TO LEAN THE MASTER STOP BLOCK ON THE FIRST LOAD HOLDER AND LOWER THE SLAVE SWING ARM TO THE GROUND.

NOTE : AN AIR EXHAUST NOISE FROM THE HYDRAULIC SYSTEM WILL BE AUDIBLE BY THE AIR BLEEDER.

6. ACTIVATE THE HYDRAULIC UNIT TO RISE THE LIFTING ARMS APPROXIMATELY 4" ABOVE THE GROUND.

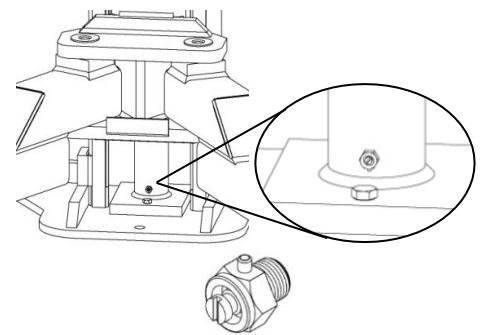

FIGURE 12 : AIR BLEEDER

MAN-NT-20000-SYM-C01-E

7. PUSH DOWN PRESSURE RELEASE HANDLE OF THE HYDRAULIC UNIT TO LOWER THE LIFTING ARMS COMPLETELY TO THE GROUND.
8. REPEAT STEPS 6 AND 7 UNTIL THE DESCENT OF SLAVE SWING ARMS IS FLUENT (ABOUT 2 OR 3 TIMES).
9. ACTIVATE THE HYDRAULIC UNIT TO RISE THE LIFTING ARMS APPROXIMATELY 4" ABOVE THE GROUND
10. WITH A FLAT SCREWDRIVER, CLOSE THE AIR BLEEDER IN CLOCKWISE.
11. ACTIVATE THE HYDRAULIC UNIT TO RISE THE SLAVE SWING ARMS TO THE HEIGHT OF THE MASTERS.
12. CLOSE THE LEVELLING VALVE.
13. ACTIVATE THE HYDRAULIC UNIT TO RISE THE LIFTING ARMS APPROXIMATELY 2" HIGHER.
14. PRESS THE UNLOCKING VALVE AND THEN PUSH DOWN PRESSURE RELEASE HANDLE, BOTH PRESSING THEM TO LOWER THE SWING ARMS TO THE GROUND. **SEE FIGURE 13.**
15. VERIFY THE OIL LEVEL. ADD OIL AS NECESSARY. (UP TO 1/2" OF THE HYDRAULIC VENT CAP)

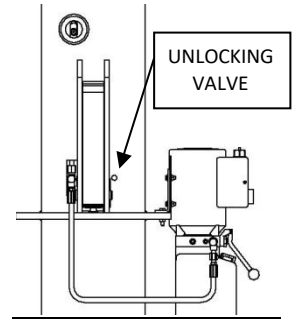

FIGURE 13 : UNLOCKING VALVE

TEST UNDER PRESSURE

(SWING ARM RESTRAINT, SNAP RING AND 2 REMAINING ANCHOR INSTALLATION)

| | |
|------------------|--|
| ⚠ WARNING | IN NO CASE, THE OIL LEAKAGE TEST SHOULD BE PERFORMED ON AN EMPTY HYDRAULIC LINE. |
|------------------|--|

1. ACTIVATE THE HYDRAULIC UNIT UNTIL THE SWING ARMS ARE AT WORKING HEIGHT.
2. SWING ARM RESTRAINTS AND SNAP RINGS ON SWING ARM PIN INSTALLATION.

| SWING ARM RESTRAINTS INSTALLATION | | SNAP RINGS INSTALLATION ON SWING ARMS PIN |
|--|--|---|
| STEP 1 | STEP 2 | STEP 1 |
| | | |
| <ol style="list-style-type: none"> 1. INSERT THE 4 SWING ARM RESTRAINTS TO THE 2 ATTACHMENT POINTS (#2). 2. INSERT AXE CHAPES (#1). 3. INSERT COTTER PINS (#3). | <p>BEND THE 8 COTTER PINS WITH PLIERS.</p> | <p>INSTALL THE SNAP RINGS ON THE 4 SWING ARM PIN.</p> |

3. ENSURE THAT THE SWING ARMS RESTRAINTS ARE FUNCTIONAL :
 - 3.1 VERIFY IF THE AUTOMATIC LATCHING SYSTEM OF THE FOUR SWING ARMS RESTRAINT IS LOCKED.
 - 3.2 PUSH AND PULL ON THE SWING ARMS ; THE SWING ARMS MUST NOT MOVE.
4. ACTIVATE THE HYDRAULIC UNIT UNTIL THE LIFTING ARMS ARE AT THE MAXIMUM HEIGHT.
5. PUSH DOWN PRESSURE RELEASE HANDLE TO RELEASE PRESSURE OF HYDRAULIC SYSTEM.
6. OPEN THE LEVELLING VALVE COMPLETELY.
7. ACTIVATE THE HYDRAULIC UNIT AND MAINTAIN IT UNDER PRESSURE SO THAT THE SWING ARMS REMAIN AT THE MAXIMUM HEIGHT FOR AT LEAST 5 SECONDS.
8. VERIFY VISUALLY THE HYDRAULIC LINE (HYDRAULIC UNIT, CYLINDERS AND LINE BETWEEN COLUMNS) IS FREE OF OIL LEAKAGE.

| | |
|------------------|--|
| ⚠ WARNING | NEVER USE BARE HANDS TO DETECT OIL LEAKS ON THE HYDRAULIC LINE. HYDRAULIC OIL FROM THE HIGH-PRESSURE SYSTEM MAY PERFORATE THE SKIN OR CAUSE SERIOUS INJURY. |
|------------------|--|

9. PUSH DOWN PRESSURE RELEASE HANDLE TO RELEASE PRESSURE OF HYDRAULIC SYSTEM.
10. VERIFY MANUALLY IF THE REAR PART OF BOTH CYLINDERS ARE FREE OF OIL LEAKAGE.
11. CLOSE THE LEVELLING VALVE COMPLETELY.

MAN-NT-20000-SYM-C01-E

12. PUSH DOWN PRESSURE RELEASE HANDLE OF THE HYDRAULIC UNIT TO LOWER THE SWING ARMS ON THE NEAREST LOAD HOLDER. (WITHOUT PRESSING THE UNLOCKING VALVE)
13. INSTALL THE 2 REMAINING ANCHORS AT POSITION # 8 AT EACH COLUMN BASE. RESUME STEPS #5 – ANCHORS INSTALLATION AND #9 – FINISHING ANCHORS INSTALLATION OF COLUMN INSTALLATION SECTION.
14. ACTIVATE THE HYDRAULIC UNIT TO RISE THE LIFTING ARMS APPROXIMATELY 2" HIGHER.
15. PRESS THE UNLOCKING VALVE AND THEN PUSH DOWN PRESSURE RELEASE HANDLE, BOTH PRESSING THEM TO LOWER THE SWING ARMS TO THE GROUND.
16. CHECK FOR OIL LEAKAGE ON OVERALL HYDRAULIC LINE OF THE LIFT AND ON THE FLOOR.
17. VERIFY IF THE AUTOMATIC SWING ARM RESTRAINTS HAS UNENGAGED.
 - 17.1 VERIFY IF THE AUTOMATIC LATCHING SYSTEM OF THE FOUR SWING ARMS RESTRAINT IS UNLOCKED.
 - 17.2 PUSH AND PULL ON THE SWING ARMS ; THE SWING ARMS SHOULD MOVE.

SWING ARMS LEVELLING

1. REMOVE LIFTING PADS AND SOCKET ADAPTORS FROM THE LIFTING ARMS.
2. ON THE MASTER POST, FULLY OPEN THE LEVELLING VALVE.
3. PUSH DOWN PRESSURE RELEASE HANDLE OF THE HYDRAULIC UNIT TO LOWER THE LIFTING ARMS COMPLETELY TO THE GROUND.
4. CLOSE THE LEVELLING VALVE COMPLETELY.

LEVELLING STEP

5. ACTIVATE THE HYDRAULIC UNIT TO RISE THE LIFTING ARMS APPROXIMATELY 8 ABOVE THE GROUND (A CLUNKING SOUND FROM THE RETRACTABLE LOAD HOLDERS SHOULD BE HEARD),
6. OPEN THE LEVELLING VALVE COMPLETELY.
7. PUSH DOWN PRESSURE RELEASE HANDLE TO LOWER THE LIFTING ARMS, SO AS TO REST THE STOP BLOCKS OF THE CARRIAGE DIRECTLY ONTO THE RETRACTABLE LOAD HOLDERS.
8. MAKE SURE THAT THE STOP BLOCK OF THE MASTER CARRIAGE IS CORRECTLY IMMOBILIZED ON THE RETRACTABLE LOAD HOLDERS. PRESS THE PNEUMATIC UNLOCKING VALVE:
 - IF THE MASTER LOAD HOLDER REMAINS IMMOBILIZED : THE STOP BLOCK IS LOCKED.
 - IF MASTER LOAD HOLDER MOVES, GO BACK TO STEP 7.
9. EXTEND THE LIFTING ARMS AS FAR AS POSSIBLE. **SEE FIGURE 14.**
10. SLAVE SWING ARMS MUST BE 1/4 "OR (-) LOWER THAN THE MASTER LIFTING ARMS. **SEE FIGURE 15.**

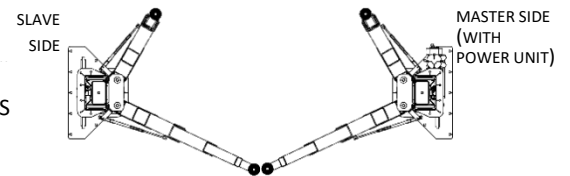

FIGURE 14 : SWING ARMS EXTENDED

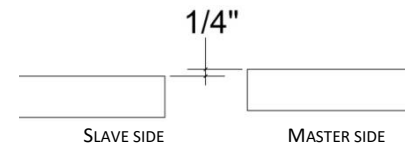

FIGURE 15 : COMPARATIVE HEIGHT

NOTE : IF THE SLAVE SWING ARMS IS HIGHER THAN THE MASTER SIDE, CONTACT THE MANUFACTURER.

11. ACTIVATE THE HYDRAULIC UNIT IN SHORT INTERVAL (2 SEC) TO RISE THE SLAVE SIDE UNTIL BOTH SIDES ARE AT THE SAME HEIGHT.
12. CLOSE THE LEVELLING VALVE COMPLETELY.

NOTE : DURING OPERATING TESTS, VIBRATION OR SAGGED DESCENT OF SWING ARMS INDICATES THAT THERE IS RESIDUAL AIR IN THE HYDRAULIC SYSTEM. IF IT IS THE CASE, RESUME STEPS 1 TO 15 – TO BLEED AIR OF HYDRAULIC CONDUITS OF OPERATING TESTS SECTION.

13. ACTIVATE THE POWER UNIT TO RISE THE LIFTING ARMS APPROXIMATELY 2" TO DISENGAGE THE STOP BLOCKS OF THE LOAD HOLDERS
14. PRESS THE UNLOCKING VALVE AND THEN PUSH DOWN PRESSURE RELEASE HANDLE, BOTH PRESSING THEM TO LOWER THE SWING ARMS TO THE GROUND.

NOTE: A HYDRAULIC SYSTEM IS CONSIDERED "ZERO LEAK", ALTHOUGH A FEW DROPS MAY FLOW OUT WITH USE.

THE COLUMNS SYNCHRONISM IS BASED ON A CLOSED HYDRAULIC SYSTEM. HOWEVER, WHEN A HYDRAULIC SYSTEM INDUCES THE PARTS MOVEMENT, SO-CALLED "NORMAL" OIL LOSSES CAN OCCUR DURING THE LIFT OPERATION AND CAN LEAD TO HYDRAULIC SYSTEM DESYNCHRONIZATION.

IT IS IMPORTANT TO ALWAYS LEAN THE CARRIAGES STOP BLOCKS ON THE LOAD HOLDERS TO SLOW DOWN THE SWING ARMS DESYNCHRONISM.

IT IS RECOMMENDED TO PROCEED TO THE SWING ARMS LEVELLING OF THE LIFT AS NEEDED.

OPERATING TEST WITH A TYPICAL VEHICLE

1. SELECT A TYPICAL VEHICLE WITH A WEIGHT AS CLOSE AS POSSIBLE TO THE LIFT CAPACITY.

VEHICLE ENTRANCE IN WORK BAY :

- 2. RETRACT THE EXTENSION OF THE SWING ARMS TO THE MINIMUM AND OPEN AS FAR AS POSSIBLE TO CLEAR THE SPACE BETWEEN THE COLUMNS. SEE **FIGURE 16**.
- 3. DRIVE IN THE TYPICAL VEHICLE IN THE WORK BAY AND IMMOBILIZE IT WHEN THE CENTER OF GRAVITY IS LOCATED BETWEEN THE 2 COLUMNS.
- 4. PARK THE VEHICLE TRANSMISSION TO NEUTRAL POSITION. TURN OFF THE VEHICLE. LOWER THE CONDUCTOR SIDE WINDOW. CLOSE ALL THE DOORS.

NOTE: THE TRANSMISSION IS IN NEUTRAL POSITION TO EASILY MOVE THE VEHICLE WITHOUT STARTING THE ENGINE IF THE CENTER OF GRAVITY IS NOT WELL CENTRED.

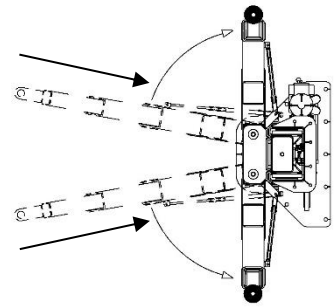



FIGURE 16 : SWING ARMS POSITION

| | |
|--|--|
|  CAUTION | IF THE FLOOR IS NOT LEVEL AND DOES NOT PERMIT TO LEAVE THE TRANSMISSION IN NEUTRAL POSITION WITHOUT A RISK OF INVOLUNTARY BEARING, ENGAGE THE HAND BREAK OR PUT WHEEL CHOCK. |
|--|--|

MAXIMUM VEHICLE RAISING :

- 5. INSTALL THE LIFTING PADS AND EXTENSION SOCKETS IN THE HOLES AT THE END OF THE SWING ARMS
- 6. MOVE SWING ARMS BELOW THE VEHICLE.
- 7. ALIGN THE 4 LIFTING PADS UNDER LIFTING POINTS RECOMMENDED BY THE VEHICLE’S MANUFACTURER.
- 8. ACTIVATE THE HYDRAULIC UNIT TO RISE THE TYPICAL VEHICLE TIRES ABOUT 1" ABOVE THE GROUND.
- 9. VERIFY IF THE 4 LIFTING PADS ARE COMPLETELY IN CONTACT WITH THE LIFTING POINTS RECOMMENDED BY THE VEHICLE’S MANUFACTURER. PUSH LATERALLY ON THE VEHICLE TO CHECK ITS STABILITY AND LEVELLING ; THE VEHICLE MUST BE STABLE AND LEVELLED. IF IT IS NOT THE CASE :
 - 9.1 PUSH DOWN PRESSURE RELEASE HANDLE TO LOWER THE LIFTING ARMS TO THE GROUND.
 - 9.2 ADJUST THE HEIGHT OF THE LIFTING PADS BY ADDING OR REMOVING EXTENSION SOCKETS TO PUT THE VEHICLE UP AT LEVEL AND TO HAVE THE SHORTEST DISTANCE BETWEEN LIFTING PADS AND THE LIFTING POINTS RECOMMENDED BY THE VEHICLE’S MANUFACTURER. SEE **FIGURE 17**.
 - 9.3 RESUME STEPS 6 TO 9.
- 10. PUSH DOWN PRESSURE RELEASE HANDLE OF THE HYDRAULIC UNIT TO LOWER THE VEHICLE AND TO LEAN THE CARRIAGE STOP BLOCKS ON THE NEAREST LOAD HOLDER. (WITHOUT PRESSING THE UNLOCKING VALVE)

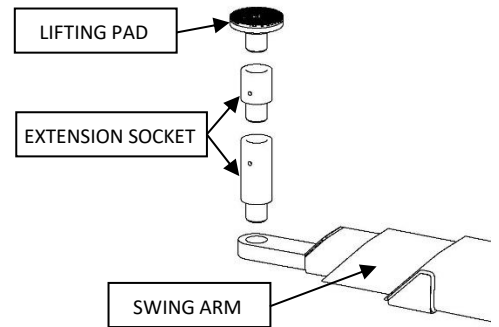

FIGURE 17 : EXTENSION SOCKET INSERTING

MAXIMUM VEHICLE DESCENT : (TO THE GROUND)

- 11. ACTIVATE THE HYDRAULIC UNIT TO RISE THE VEHICLE OF 2" TO DISENGAGE THE STOPS BLOCKS FROM THE LOAD HOLDERS.
- 12. PRESS THE UNLOCKING VALVE AND THEN PUSH DOWN PRESSURE RELEASE HANDLE, BOTH PRESSING THEM TO LOWER THE SWING ARMS TO THE GROUND.

VEHICLE EXIT FROM WORK BAY :

- 13. RETRACT THE EXTENSION OF THE SWING ARMS TO THE MINIMUM AND OPEN AS FAR AS POSSIBLE TO CLEAR THE SPACE BETWEEN THE COLUMNS. SEE **FIGURE 16**.
- 14. DRIVE OUT THE TYPICAL VEHICLE OUT OF THE WORK BAY.
- 15. CHECK FOR OIL LEAKAGE ON OVERALL HYDRAULIC LINE OF THE LIFT AND ON THE FLOOR.

INSTALLER : RETURN THIS MANUAL WITH OTHER INSTRUCTIONAL MATERIALS FURNISHED WITH THE LIFT AND GIVE TO OWNER/USER/EMPLOYER.

OPERATING INSTRUCTIONS

REFER TO : ANSI/ALI ALOIM :STANDARD FOR AUTOMOTIVE LIFTS - SAFETY REQUIREMENTS FOR OPERATION, INSPECTION AND SERVICE

OWNER / EMPLOYER RESPONSIBILITY

OWNER / EMPLOYER :

- ☑ SHALL ENSURE THAT LIFT OPERATORS ARE QUALIFIED AND THAT THEY ARE TRAINED IN THE SAFE USE AND OPERATION OF THE LIFT USING THE MANUFACTURER'S OPERATING INSTRUCTIONS: ALI-SM, LIFTING IT RIGHT – A SAFETY MANUAL FROM THE AUTOMOTIVE LIFT INSTITUTE, ALI-ST, AUTOMOTIVE LIFT SAFETY TIPS, ANSI/ALI ALOIM, STANDARD FOR AUTOMOTIVE LIFTS – SAFETY REQUIREMENT FOR OPERATION, INSPECTION AND MAINTENANCE, ALI/WL SERIES, ALI UNIFORM WARNING LABEL DECALS/PLACARDS; AND IN THE CASE OF FRAME ENGAGING LIFTS, ALI-LP, QUICK REFERENCE GUIDE - VEHICLE LIFTING POINTS FOR FRAME ENGAGING LIFTS.
- ☑ SHALL ESTABLISH PROCEDURES TO PERIODICALLY INSPECT THE LIFT IN ACCORDANCE WITH THE LIFT MANUFACTURER'S INSTRUCTIONS OR ANSI/ALI ALOIM; AND THE EMPLOYER SHALL ENSURE THAT LIFT INSPECTORS ARE QUALIFIED AND THAT THEY ARE ADEQUATELY TRAINED IN THE INSPECTION OF THE LIFT.
- ☑ SHALL ESTABLISH PROCEDURES TO PERIODICALLY MAINTAIN THE LIFT IN ACCORDANCE WITH THE LIFT MANUFACTURER'S INSTRUCTIONS OR ANSI/ALI ALOIM ; AND THE EMPLOYER SHALL ENSURE THAT LIFT MAINTENANCE PERSONNEL ARE QUALIFIED AND THAT THEY ARE ADEQUATELY TRAINED IN THE MAINTENANCE OF THE LIFT.
- ☑ SHALL MAINTAIN THE PERIODIC INSPECTION AND MAINTENANCE RECORDS RECOMMENDED BY THE MANUFACTURER OR ANSI/ALL ALOIM.
- ☑ SHALL DISPLAY THE LIFT MANUFACTURER'S OPERATING INSTRUCTIONS, ALI/SM, ALI/ST, ANSI/ALI ALOIM; AND IN THE CASE OF FRAME ENGAGING LIFTS, ALI-LP-GUIDE, IN A CONSPICUOUS LOCATION IN THE LIFT AREA CONVENIENT TO THE OPERATOR.
- ☑ SHALL PROVIDE NECESSARY LOCKOUT/TAG OUT MEANS FOR ENERGY SOURCES PER ANSI Z244.1 – SAFETY REQUIREMENTS FOR THE LOCKOUT/TAGOUT OF ENERGY SOURCES, BEFORE BEGINNING ANY LIFT REPAIRS.
- ☑ SHALL NOT MODIFY THE LIFT IN ANY MANNER WITHOUT THE PRIOR WRITTEN CONSENT OF THE MANUFACTURER.
- ☑ SHALL ENSURE THAT REPLACE WORN, DAMAGED OR BROKEN PARTS WITH PARTS APPROVED BY THE ORIGINAL EQUIPMENT MANUFACTURER OR WITH PARTS MEETING ORIGINAL MANUFACTURER SPECIFICATIONS.

IMPORTANT SAFETY INSTRUCTIONS

1. READ ALL INSTRUCTIONS.
2. INSPECT THE LIFT DAILY AND MONTHLY. NEVER OPERATE THE LIFT IF IT IS MALFUNCTIONS OR HAS BROKEN OR DAMAGED PARTS. USE ONLY LIFT PLANNED SERVICE PERSONNEL AND GENUINE PARTS TO MAKE REPAIRS.
3. THOROUGHLY TRAIN ALL EMPLOYEES IN USE AND CARE OF LIFT, USING MANUFACTURER INSTALLATION AND OPERATING INSTRUCTIONS MANUAL AND ALI/SM – LIFTING IT RIGHT AND ALI/ST – SAFETY TIPS SUPPLIED WITH THE LIFT.
4. NEVER ALLOW UNAUTHORIZED OR UNTRAINED PERSON PERSONS TO POSITION VEHICLE OR OPERATE LIFT.
5. PROHIBIT UNAUTHORIZED PERSON FROM BEING IN SHOP AREA WHILE LIFT IS IN USE.

NOTE : SINCE 1994, AUTOMOTIVE'S MANUFACTURERS MAY HAVE IDENTIFIED THEIR RECOMMENDED LIFTING POINTS ON VEHICLES. THE POINTS ARE IDENTIFIABLE ON A LABEL ON THE VERTICAL LOCK FACE PLATE OF THE FRONT PASSENGER SIDE DOOR, IN GLOVE BOX, OR UNDER THE HOOD (SAE J2184 – VEHICLE LIFT POINTS FOR SERVICE GARAGE LIFTING).

THE LIFTING POINTS ARE IDENTIFIED BY HOLES, BOSSES, AND/OR DEPRESSIONS IN THE SHAPE OF AN EQUILATERAL TRIANGLE OR A SUPPLEMENTAL, SUCH AS A LIFT PAD, IDENTICAL TO THE TRIANGLE UNDER CAR BODY. REFER TO ALI/LP-GUIDE OF THE LAST 20 YEARS CAR MODELS. SEE **FIGURE 18**.

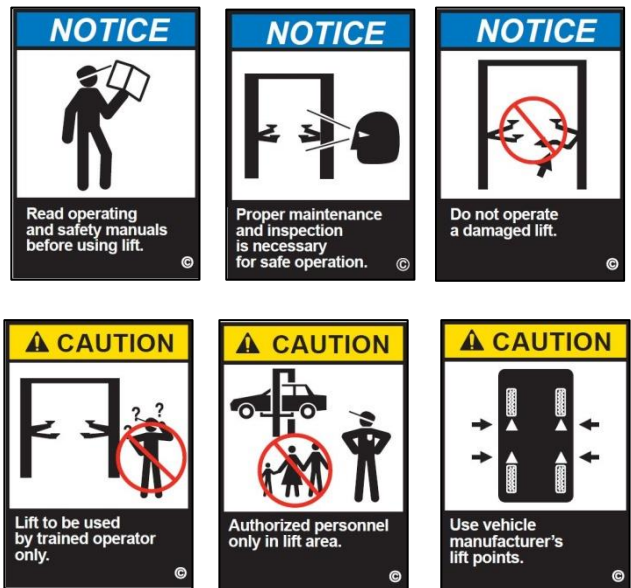

MAN-NT-20000-SYM-C01-E

6. NEVER EXCEED 12" HIGH OF EXTENSION SOCKETS. See **FIGURE 19**.
7. MAKE SURE LIFTING POINTS UNDER THE VEHICLE ARE FREE OF RUST, ICE, OIL OR BREAKAGE.
8. LOAD VEHICLE CAREFULLY. POSITION LIFT ADAPTERS TO CONTACT AT THE VEHICLE MANUFACTURER'S RECOMMENDED LIFT POINTS. RAISE LIFT UNTIL ADAPTERS CONTACT VEHICLE. CHECK ADAPTERS TO SECURE CONTACT WITH VEHICLE. RAISE LIFT TO DESIRED WORKING HEIGHT.

NOTE : THE CENTER OF GRAVITY IS THE POINT BETWEEN THE FRONT AND REAR OF THE VEHICLE WHERE THE WEIGHT IS DISTRIBUTED EQUALLY. EACH VEHICLE HAVE A DIFFERENT CENTER OF GRAVITY LOCATION DUE TO WEIGHT DISTRIBUTION, WHEEL BASE, DRIVE TRAIN'S LOCATION AND OTHER FACTOR SUCH AS CARGO.

THE CENTER OF GRAVITY ON REAR-WHEEL DRIVE (RWD) PASSENGER CARS IS BELOW THE DRIVER'S SEAT. ON FRONT-WHEEL DRIVE (FWD) PASSENGER CARS, THE CENTER OF GRAVITY IS SLIGHTLY IN FRONT OF THE DRIVER'S SEAT.

9. USE THE LIFT ONLY FOR THE PURPOSE FOR WHICH IT WAS DESIGNED FOR.
10. ALWAYS KEEP AREA LIFT FREE OF TOOLS, DEBRIS, GREASE OR OIL.
11. DO NOT REMOVE OR DISABLE SWING ARM RESTRAINTS.
12. DO NOT PERMIT ANYONE ON LIFT OR INSIDE VEHICLE WHEN IT IS EITHER BEING RAISED OR LOWERED.

13. NEVER OVERLOAD LIFT. LIFT CAPACITY IS SHOWN ON THE NAMEPLATE AFFIXED TO THE LIFT.
14. DO NOT HIT OR RUN OVER LIFT ARMS OR ADAPTERS. THIS COULD DAMAGE LIFT OR VEHICLE. BEFORE DRIVING IN OR DRIVING OUT THE VEHICLE OF THE LIFT BAY, POSITION ARMS AND ADAPTERS TO PROVIDE UNOBSTRUCTED ENTRANCE ONTO LIFT.

15. ALL LIFT ACCESSORIES SUPPLIED SHOULD STRICTLY BE USED FOR THE SPECIFIED MODEL AND BE ALI CERTIFIED. THE USE OF LIFT ACCESSORIES OF ANOTHER BRAND AND/OR NON ALI CERTIFIED ON A GIROLIFT WILL VOID ALI CERTIFICATION AND CANADA HYDRAULIQUE EQUIPEMENT INC WARRANTY.
16. DO NOT GO UNDER THE VEHICLE IF LOCKING LATCHES OF THE SWING ARM RESTRAINTS ARE NOT ENGAGED.
17. DO NOT BLOCK OPEN OR OVERRIDE SELF-CLOSING LIFT CONTROLS; THEY ARE DESIGNED TO RETURN TO THE "OFF" POSITION OR NEUTRAL POSITION WHEN RELEASED.

18. BEFORE LIFTING AN UNUSUAL VEHICLE (LIMOUSINE, RV'S, LONG WHEELBASE AND SHORT WHEELBASE VEHICLES, ETC.) OR USE SPECIAL ADAPTERS, CONTACT THE LIFT MANUFACTURER.
19. CARE MUST BE TAKEN AS BURNS CAN OCCUR FROM TOUCHING HOT PARTS.

20. DO NOT OPERATE EQUIPMENT WITH A DAMAGED CORD OR IF THE EQUIPMENT HAS BEEN DROPPED OR DAMAGED – UNTIL IT HAS BEEN EXAMINED BY A TRAINED SERVICE PERSON.
21. DO NOT LET A CORD HANG OVER THE EDGE OF THE TABLE, BENCH, OR COUNTER OR COME IN CONTACT WITH HOT MANIFOLDS OR MOVING FAN BLADES.

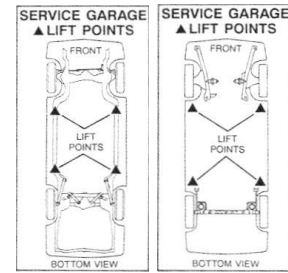

FIGURE 18 : TYPICAL LABEL DRAWING SEA J2184

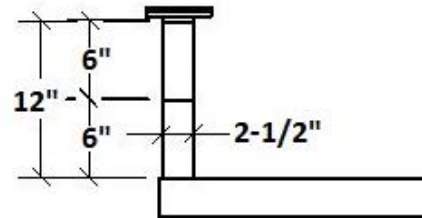

FIGURE 19 : MAXIMUM HEIGHT OF EXTENSION SOCKETS



PICTOGRAPHS AND WARNING LABELS ARE COPYRIGHTED MATERIALS USED WITH PERMISSION FROM THE AUTOMOTIVE LIFT INSTITUTE.

MAN-NT-20000-SYM-C01-E

- 22. IF AN EXTENSION CORD IS NECESSARY, A CORD WITH A CURRENT RATING EQUAL TO OR MORE THAN THAT OF THE EQUIPMENT SHOULD BE USED. CORDS RATED FOR LESS CURRENT THAN THE EQUIPMENT MAY OVERHEAT. CARE SHOULD BE TAKEN TO ARRANGE THE CORD SO THAT IT WILL NOT BE TRIPPED OVER OR PULLED.
- 23. ALWAYS UNPLUG EQUIPMENT FROM ELECTRICAL OUTLET WHEN NOT IN USE. NEVER USE THE CORD TO PULL THE PLUG FROM THE OUTLET. GRASP PLUG AND PULL TO DISCONNECT.
- 24. LET EQUIPMENT COOL COMPLETELY BEFORE PUTTING AWAY. LOOP CORD LOOSELY AROUND EQUIPMENT WHEN STORING.
- 25. TO REDUCE THE RISK OF FIRE, DO NOT OPERATE EQUIPMENT IN THE VICINITY OF OPEN CONTAINERS OF FLAMMABLE LIQUIDS (GASOLINE).
- 26. ADEQUATE VENTILATION SHOULD BE PROVIDED WHEN WORKING ON OPERATING INTERNAL COMBUSTION ENGINES.
- 27. KEEP HAIR, LOOSE CLOTHING, FINGERS, AND ALL PARTS OF BODY AWAY FROM MOVING PARTS.
- 28. TO REDUCE THE RISK OF ELECTRIC SHOCK, DO NOT USE ON WET SURFACES OR EXPOSE TO RAIN.
- 29. ALWAYS WEAR SAFETY GLASSES. EVERYDAY EYEGLASSES ONLY HAVE IMPACT RESISTANT LENSES, THEY ARE NOT SAFETY GLASSES.
- 30. TO REDUCE THE RISK OF ELECTRIC SHOCK OR FIRE, NEVER OVERLOAD RECEPTACLES. REFER TO MARKINGS FOR THE PROPER LOAD ON RECEPTACLES.

SAVE THESE INSTRUCTIONS

NOTE : THESE SAFETY INSTRUCTIONS DO NOT COVER ALL RISKS OF A LIFT USE. IF AN INJURY HAS OCCURRED OR COULD HAVE HAPPENED, DETERMINE THE CAUSE TO PREVENT IT. ALWAYS REMAIN WATCHFUL.

FOR ADDITIONAL SAFETY INSTRUCTIONS : VARIOUS LIFT MODELS, LABELS, LIFTING PREPARATION, VEHICLE POSITIONING, VEHICLE LIFTING METHODS, LOAD CAPACITY, EMERGENCY PROCEDURES, VEHICLE LOWERING, LIFTING LIMITS, MAINTENANCE, WORKSHOP BEST PRACTICES. TRAINING AND OWNER / EMPLOYER RESPONSIBILITY REFER TO : ALI/SM, ALI/ST, ALI/LP-GUIDE ANSI/ALI ALOIM AND SAE J2184.

LIFT OPERATION

NEVER USE A GIROLIFT IF THE LIFT :

| ⚠ CAUTION | PROBLEMS | EXPLANATIONS |
|-----------|---------------------------------------|---|
| ⚠ CAUTION | SLOWLY RISES WHEN NOT IN USE. | ELECTRICAL PROBLEM ON POWER UNIT THAT CAN NO LONGER BE CONTROLLED AT THE LIFT RAISING. |
| | VIBRATES OR SHAKES UP AT THE RAISING. | PRESENCE OF AIR IN THE HYDRAULIC LINE ; THE VIBRATIONS MAY MOVE OR DROP OFF THE VEHICLE OUT OF THE LIFT. |
| | LEAKS AT THE HYDRAULIC CONDUITS. | DEPENDING OF THE SEVERITY AND THE LOCATION OF THE LEAK, A REPAIR SHOULD BE PERFORMED BY A LIFT PLANNED SERVICE PERSONNEL. |

VEHICLE ENTRANCE IN WORK BAY :

1. RETRACT THE EXTENSION OF THE SWING ARMS TO THE MINIMUM AND OPEN AS FAR AS POSSIBLE TO CLEAR THE SPACE BETWEEN THE COLUMNS. SEE **FIGURE 16**.
2. DRIVE IN THE VEHICLE IN THE WORK BAY AND IMMOBILIZE IT WHEN THE CENTER OF GRAVITY IS LOCATED BETWEEN THE 2 COLUMNS.
3. LEAVE THE VEHICLE TRANSMISSION TO NEUTRAL POSITION. TURN OFF THE VEHICLE. LOWER THE CONDUCTOR SIDE WINDOW. CLOSE THE DOORS.

NOTE: THE TRANSMISSION IS IN NEUTRAL POSITION TO EASILY MOVE THE VEHICLE WITHOUT STARTING THE ENGINE IF THE CENTER OF GRAVITY IS NOT WELL CENTRED.

| | |
|-----------|--|
| ⚠ CAUTION | IF THE FLOOR IS NOT LEVEL AND DOES NOT PERMIT TO LEAVE THE TRANSMISSION IN NEUTRAL POSITION WITHOUT A RISK OF INVOLUNTARY BEARING, ENGAGE THE HAND BREAK OR PUT WHEEL CHOCK. |
|-----------|--|

VEHICLE ASCENT:

4. INSTALL THE LIFTING PADS AND EXTENSION SOCKETS IN THE HOLES AT THE END OF THE SWING ARMS. SEE **FIGURE 17**.
5. MOVE SWING ARMS BELOW VEHICLE.
6. ALIGN THE 4 LIFTING PADS UNDER LIFTING POINTS RECOMMENDED BY VEHICLE’S MANUFACTURER. SEE **FIGURE 18**.
7. ACTIVATE THE HYDRAULIC UNIT TO RISE THE VEHICLE TIRES ABOUT 1" ABOVE THE GROUND. SEE **FIGURE 20**.

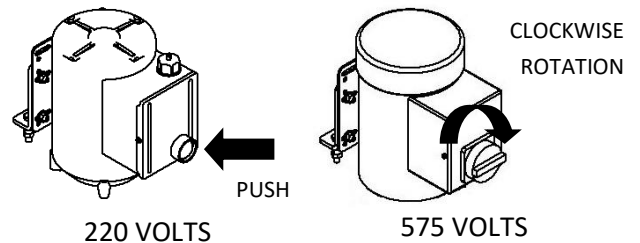

FIGURE 20 : POWER UNIT ACTIVATION

MAN-NT-20000-SYM-C01-E

8. VERIFY IF THE 4 LIFTING PADS ARE COMPLETELY IN CONTACT WITH THE LIFTING POINTS RECOMMENDED BY THE VEHICLE'S MANUFACTURER. PUSH Laterally ON THE VEHICLE TO CHECK ITS STABILITY AND LEVELLING ; THE VEHICLE MUST BE STABLE AND LEVELLED. IF IT IS NOT THE CASE :
 - 8.1 PUSH DOWN PRESSURE RELEASE HANDLE TO LOWER THE LIFTING ARMS TO THE GROUND.
 - 8.2 ADJUST THE LIFTING PADS HEIGHT BY ADDING OR REMOVING EXTENSION SOCKETS TO PUT THE VEHICLE UP TO THE LEVEL AND TO HAVE THE SHORTEST DISTANCE BETWEEN LIFTING PADS AND THE LIFTING POINTS RECOMMENDED BY THE VEHICLE'S MANUFACTURER. SEE **FIGURE 17**.
 - 8.3 RESUME STEPS 5 TO 8.
9. ACTIVATE THE HYDRAULIC UNIT UP TO THE DESIRED HEIGHT.

LOAD MAINTAINING :

10. PUSH DOWN PRESSURE RELEASE HANDLE OF THE HYDRAULIC UNIT TO LOWER THE VEHICLE AND TO LEAN THE CARRIAGE STOP BLOCKS ON THE NEAREST LOAD HOLDER. (WITHOUT PRESSING THE UNLOCKING VALVE)

IMPORTANT

LOAD HOLDERS ARE USED TO :

- STABILIZE AND MAINTAIN THE VEHICLE AT LEVEL ON A MECHANICAL SUPPORT.
- REDUCE EARLY WEAR OF COMPONENTS AND HYDRAULIC FITTINGS ; ALLOW THE HYDRAULIC SYSTEM TO BE FREE OF HYDRAULIC PRESSURE BETWEEN EACH USE.
- INCREASE USER AND EQUIPMENT SAFETY AROUND AND UNDER THE LIFT IN CASE OF A MECHANICAL BREAK.

VEHICLE DESCENT :

11. ACTIVATE THE HYDRAULIC UNIT TO RISE THE VEHICLE OF 2" TO DISENGAGE THE STOPS BLOCKS FROM THE LOAD HOLDERS.
12. PRESS THE UNLOCKING VALVE AND THEN PUSH DOWN PRESSURE RELEASE HANDLE, BOTH PRESSING THEM TO LOWER THE SWING ARMS TO INTERMEDIATE HEIGHT.
13. TO MAINTAIN THE LOAD, RESUME STEP 10.
14. PRESS THE UNLOCKING VALVE AND THEN PUSH DOWN PRESSURE RELEASE HANDLE, BOTH PRESSING THEM TO LOWER THE SWING ARMS TO THE GROUND.

VEHICLE EXIT FROM WORK BAY :

15. RETRACT THE EXTENSION OF THE SWING ARMS TO THE MINIMUM AND OPEN AS FAR AS POSSIBLE TO CLEAR THE SPACE BETWEEN THE COLUMNS. SEE **FIGURE 16**.
16. DRIVE OUT THE OF THE WORK BAY.

MAINTENANCE AND INSPECTION INSTRUCTIONS

REFER TO : ANSI/ALI ALOIM :STANDARD FOR AUTOMOTIVE LIFTS - SAFETY REQUIREMENTS FOR OPERATION, INSPECTION AND SERVICE

MAINTENANCE INSTRUCTIONS

- BE FAMILIAR WITH LIFT MAINTENANCE PROCEDURES.
- PERMIT ONLY TRAINED LIFT SERVICE PERSONNEL TO PERFORM MAINTENANCE OF GIROLIFT.

WORKSHOP BEST PRACTICES

REFER TO : ANSI/ALI SM : LIFTING IT RIGHT – A SAFETY MANUAL FROM THE AUTOMOTIVE LIFT INSTITUTE

1. RISE THE SWING ARM 3' ABOVE THE GROUND TO CLEAN THE FLOOR TO AVOID DUST IN THE SLOTS OF THE SWING ARMS, IN THE COLUMNS SLIDERS OR IN MECHANISM OF AUTOMATIC SWING ARM RESTRAINTS.

LIFT CLEANING



NEVER USE WATER OR CORROSIVE PRODUCTS TO CLEAN; THESE SOLUTIONS ACCELERATE THE CORROSION AND CAN CONTRIBUTE TO PAINT PEELING.

LIGHT CLEANING

NOTE : USE THIS METHOD IF THE LIFT IS MAINTAINED DAILY.

1. DAILY CLEAN THE LIFT WITH A CLEAN AND DRY RAG, INCLUDING CYLINDER BASES AND COLUMN BASES.
2. LUBRICATE CYLINDER BASES AND COLUMN BASES. SEE MAINTENANCE AND INSPECTION INSTRUCTIONS – LIFT LUBRICATION.

HEAVY-DUTY CLEANING

NOTE: USE THIS METHOD IF LIFT CLEANING HAS BEEN NEGLECTED OR TO REMOVE STUBBORN RESIDUE

1. DAILY CLEAN THE LIFT WITH A CLEAN AND DRY RAG, INCLUDING CYLINDER BASES AND COLUMNS. SCRAPE IF NEEDED.
2. COAT CYLINDER BASES AND COLUMN BASES WITH BRAKE CLEANER TO DISLodge STUBBORN RESIDUE.



QUICKLY REMOVE THE BRAKE CLEANER; THIS PRODUCT ACCELERATES PAINT PEELING.

3. CLEAN WITH A DRY AND CLEAN RAG.
4. LUBRICATE CYLINDER BASES AND COLUMN BASES. SEE MAINTENANCE AND INSPECTION INSTRUCTIONS – LIFT LUBRICATION.

LIFT LUBRICATION



USE A DRY LUBRICANT WITH TEFLON (E.G. JIG-A-LOO) TO LUBRICATE THE INSIDE OF THE FOUR CORNERS OF THE COLUMNS : THE USE OF ANY OTHER LUBRICANT COULD CAUSE AN ACCUMULATION OF PARTICLES, DIRT AND DUST. THIS CLUSTER BECOMES A PASTE OVER TIME AND CAN MAKE RAISING AND LOWERING OF THE COLUMNS DIFFICULT.

GENERAL LUBRICATION

1. CLEAN THE LIFT COMPONENTS BEFOREHAND. SEE MAINTENANCE AND INSPECTION INSTRUCTIONS SECTION – LIFT CLEANING.
2. LUBRICATE THE LIFT WITH A DRY TEFLON-BASED LUBRICANT: THE 4 INSIDE CORNERS OF THE COLUMNS FROM TOP TO BOTTOM, AND UNDER THE MALE PART OF LIFTING ARMS IN HIS EXTENDED POSITION.

BASES OF THE CYLINDER AND BASES COLUMNS LUBRICATION

1. CLEAN THE BASES OF THE CYLINDERS AND THE BASES OF THE COLUMNS BEFOREHAND. SEE MAINTENANCE AND INSPECTION INSTRUCTIONS – LIFT CLEANING.
2. LUBRICATE THE EDGE BETWEEN THE CYLINDER BASE AND COLUMN BASES, AND THE BOLT OF THE CYLINDER BASE WITH AUTOMATIC TRANSMISSION OIL. SEE **FIGURE 21** IN DOTTED LINE.

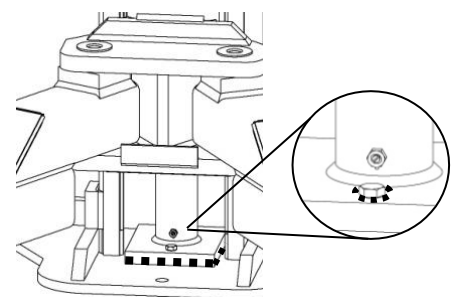

FIGURE 21 : CYLINDER BASE LUBRICATION

DAILY MAINTENANCE

NOTE : USER MAINTENANCE FORM FOR 2 POST LIFT AVAILABLE AT ANNEX 2.

1. VISUAL COMPLIANCE OF ANCHORS : VISUALLY ENSURE ALL ANCHOR NUTS AND WASHERS ARE FULLY IN CONTACT WITH THE COLUMN BASES.

IN CASE OF NON-COMPLIANCE : REAPPLY THE TIGHTENING TORQUE OF 100 POUND-FEET ON ALL ANCHORS 3/4".

NOTE : IF ANCHORS MUST BE TIGHTENED MORE THAN ONCE BETWEEN THE ANNUAL INSPECTION, CONTACT THE MANUFACTURER.
DO NOT TIGHTEN ANCHORS USELESSLY.

2. VISUAL FLOOR COMPLIANCE : ENSURE VISUALLY THAT THE ANCHORS ARE MORE THAN 6" FROM A SIGN OF FLOOR FATIGUE (CRACKS, HEAVE, DEFORMATION, ETC.).

IN CASE OF NON-COMPLIANCE : CONTACT THE LIFT MANUFACTURER.

NOTE : KEEP A RECORD OF THE CONDITION OF THE FLOOR TO FOLLOW THE EVOLUTION OF THE FLOOR WEAKNESS.

3. VISUAL COMPLIANCE OF THE HYDRAULIC SYSTEM : VISUALLY VERIFY THAT THERE IS NO APPARENT OIL LEAKS ON THE HYDRAULIC SYSTEM : HYDRAULIC LINES, CYLINDERS AND POWER UNIT.

IN CASE OF NON-COMPLIANCE : REFER TO TROUBLESHOOTING – OIL LEAKAGE.

NOTE : CONTACT THE MANUFACTURER IF THE LIFT REQUIRES FREQUENT SWING ARM LEVELLING.

4. COMPONENT COMPLIANCE : VISUALLY ENSURE THAT LIFT COMPONENTS ARE NOT DEFORMED, CRACKED, DAMAGED OR WORN : SWING ARMS, SWING ARM RESTRAINT, LIFTING PAD & RUBBER, EXTENSION SOCKETS, COLUMNS, CARRIAGE, POWER UNIT, CYLINDERS, HYDRAULIC LINE AND LOAD HOLDING DEVICES.

IN CASE OF NON-COMPLIANCE : REPLACE THE PART IMMEDIATELY OR CONTACT A LIFT PLANNED SERVICE PERSONNEL.



NEVER ATTEMPT TO STRAIGHTEN TO CORRECT ANY DEFECTIVE LIFT COMPONENTS, THIS ACTION COULD WEAKEN IT MORE.

5. SWING ARM RESTRAINTS COMPLIANCE : ENSURE SWING ARM RESTRAINTS ARE FUNCTIONAL AND IN GOOD CONDITION :

5.1 RISE LIFT AT LEAST 2-1/2" ABOVE THE GROUND.

5.2 CHECK IF THE AUTOMATIC LOCKING SYSTEM OF THE FOUR SWING ARM RESTRAINT LOCKS.

5.3 PUSH AND PULL SWING ARM RESTRAINT ; THE SWING ARM RESTRAINT MUST NOT MOVE.

IN CASE OF NON-COMPLIANCE : IMMEDIATELY REPLACE THE DEFECTIVE SWING ARM RESTRAINT.

6. BASE CLEANLINESS : ENSURE THAT CYLINDER BASES AND INSIDE OF COLUMNS ARE CLEAN AND LUBRICATED.

IN CASE OF NON-COMPLIANCE : REFER TO MAINTENANCE AND INSPECTION INSTRUCTIONS SECTION – LIFT CLEANING AND LIFT LUBRICATION

NOTE : PROPER CLEANING AND LUBRICATION OF CYLINDER BASES AND COLUMN BASES PREVENTS CORROSION AND HELP OIL LEAKAGE DETECTION FROM CYLINDERS.

MONTHLY MAINTENANCE

1. MECHANICAL COMPLIANCE OF ANCHORS : MANUALLY CHECK THE TIGHTENING OF THE ANCHOR NUTS ; IT SHOULD NOT BE POSSIBLE TO UNSCREW THEM.

IN CASE OF NON-COMPLIANCE : REAPPLY THE TIGHTENING TORQUE OF 100 POUND-FEET ON ALL ANCHORS 3/4".

NOTE : IF ANCHORS MUST BE TIGHTENED MORE THAN ONCE BETWEEN THE ANNUAL INSPECTION, CONTACT THE MANUFACTURER.
DO NOT TIGHTEN ANCHORS USELESSLY.

2. STRUCTURAL AND WELDING COMPLIANCE : EXAMINE THE STRUCTURAL COMPONENTS AND WELDS OF THE LIFT FOR SIGNS OF WORN, DEFORMATION, CRACKING OR DAMAGE.

IN CASE OF NON-COMPLIANCE : IMMEDIATELY REPLACE THE PART OR CONTACT A LIFT PLANNED SERVICE PERSONNEL.

3. SWING ARM DEFORMATION EVALUATION : VERIFY SWING ARM DEFORMATION. REFER TO ANNEX 3.

IN CASE OF NON-COMPLIANCE : IMMEDIATELY REPLACE THE SWING ARM OR CONTACT A LIFT PLANNED SERVICE PERSONNEL.

4. LABELS AND DOCUMENTATION COMPLIANCE : VERIFY THAT LABELS AND COVERS OR GUARDS ARE AFFIXED TO THE LIFT AND THE APPROPRIATE DOCUMENTS ARE IN THE WORK BAY. REFER TO ANNEX 1.

IN CASE OF NON-COMPLIANCE : OBTAIN THE MISSING ARTICLE BY CONTACTING THE MANUFACTURER.

NOTE: LABELS ON LIFT PROVIDE BASIC INFORMATION ONLY. THE SAFETY INSTRUCTIONS ARE MORE DETAILED IN THE INSTALLATION AND OPERATING INSTRUCTION MANUAL. REFER TO OPERATING INSTRUCTIONS SECTION – IMPORTANT SAFETY INSTRUCTIONS.

5. LUBRICATION : LUBRICATE LIFT. REFER TO MAINTENANCE AND INSPECTION INSTRUCTIONS SECTION– LIFT LUBRICATION.

MAN-NT-20000-SYM-C01-E

LIFT OPERATIONAL TEST

6. LOAD HOLDING DEVICES COMPLIANCE : VERIFY THE CONFORMITY OF THE ENGAGEMENT AND DISENGAGEMENT OF THE LOAD HOLDING DEVICES.

ENGAGEMENT :

- 6.1 ACTIVATE THE HYDRAULIC UNIT TO RISE THE LIFTING ARMS APPROXIMATELY 8" ABOVE THE GROUND (A CLUNKING SOUND FROM THE RETRACTABLE LOAD HOLDERS SHOULD BE HEARD).
- 6.2 PUSH DOWN PRESSURE RELEASE HANDLE TO LOWER THE LIFTING ARMS, SO AS TO REST THE STOP BLOCK OF THE MASTER CARRIAGE DIRECTLY ONTO THE MASTER RETRACTABLE LOAD HOLDER. MAKE SURE THAT THE MASTER STOP BLOCK OF THE CARRIAGE IS CORRECTLY IMMOBILIZED ON THE RETRACTABLE LOAD HOLDER. PRESS THE PNEUMATIC UNLOCKING VALVE :
 - IF THE MASTER RETRACTABLE LOAD HOLDER REMAINS IMMOBILIZED: THE STOP BLOCK IS LOCKED. MANUALLY CHECKED THE ENGAGEMENT OF THE MASTER LOAD HOLDER.
 - IF THE LOAD HOLDER DISENGAGES (AUDIBLE NOISE FROM MASTER LOAD HOLDER), REPEAT STEP 5.2.

NOTE : THE SLAVE LOAD HOLDER SHOULD NOT BE ENGAGED WITHOUT WEIGHT. IF THE SLAVE LOAD HOLDER IS ENGAGED, RESUME OPERATING TESTS SECTION – SWING ARMS LEVELLING.

DISENGAGEMENT :

- 6.3 ACTIVATE THE POWER UNIT TO RISE THE LIFTING ARMS APPROXIMATELY 2" TO DISENGAGE THE STOP BLOCK FROM THE LOAD HOLDERS.
- 6.4 PRESS THE UNLOCKING VALVE AND THEN LOWER THE RELEASE HANDLE BY BOTH KEEPING THEM TO LOWER THE LIFTING ARMS TO THE GROUND.

IN CASE OF NON-COMPLIANCE : IMMEDIATELY REPLACE THE PART OR CONTACT A LIFT PLANNED SERVICE PERSONNEL.
7. COMPLETE CYCLE OF ELEVATION : DO A COMPLETE CYCLE OF ELEVATION. VERIFY THAT THE LIFT IS WORKING PROPERLY. IDENTIFY DEFORMITIES OR ABNORMAL NOISES.

IN CASE OF NON-COMPLIANCE : IMMEDIATELY REPLACE THE PART OR CONTACT A LIFT PLANNED SERVICE PERSONNEL.

ANNUAL INSPECTION

THE LIFT MUST BE INSPECTED ANNUALLY BY A TRAINED AND EXTERNAL LIFT INSPECTOR.

TROUBLESHOOTING

| # | PROBLEMS | CAUSES | SOLUTIONS |
|--------------------------------|---|---|---|
| 1 | POWER UNIT DOES NOT RUN | 220 VOLTS AND 575 VOLTS | |
| | | 1. THE MOTOR IS NOT CONNECTED TO THE REQUIRED VOLTAGE (220 VOLTS OR 575 VOLTS). | 1. HAVE A CERTIFIED ELECTRICIAN TO CONNECT THE POWER UNIT WITH REQUIRED VOLTAGE. |
| | | 2. THE MOTOR OF THE POWER UNIT IS NOT POWERED SUPPLY : 2.1 THE FUSE IS BURNED. 2.2 THE CIRCUIT BREAKER IS OPEN. | 2.1 REPLACE THE DEFECTIVE FUSE. 2.2 RESET THE CIRCUIT BREAKER ON THE MASTER COLUMN AND/OR OF THE ELECTRICAL PANEL. |
| | | 3. THE ON/OFF SWITCH IS DEFECTIVE. | 3. HAVE A CERTIFIED ELECTRICIAN TO REPLACE THE ON/OFF SWITCH. |
| | | 4. DEFECTIVE MOTOR ON POWER UNIT. | 4. HAVE A CERTIFIED ELECTRICIAN TO VALIDATE THE DEFECT. |
| | | 5. BROKEN OR DEFECTIVE MICROSWITCH. | 5. REPLACE THE MICROSWITCH. |
| | | 6. THE MICROSWITCH IS MOVED FROM ITS BASE. | 6. REPLACE THE MICROSWITCH IN ITS BASE. |
| | | 7. THE MOTOR DOES NOT STOP : 7.1 THE ON/OFF SWITCH IS DEFECTIVE | IMMEDIATELY TURN OFF THE CIRCUIT BREAKER : 7.1 REPLACE DEFECTIVE SWITCH. |
| | | 220 VOLTS | |
| | | 7.2 THE RELAY OF THE SWITCH IS DEFECTIVE. | IMMEDIATELY TURN OFF THE CIRCUIT BREAKER : 7.2 REPLACE DEFECTIVE SWITCH. |
| 8. THE CIRCUIT BREAKER IS OFF. | 8. TURN ON THE CIRCUIT BREAKER. | | |
| 2 | POWER UNIT RUNS BUT THE LIFT DOES NOT RISE | 1. THE 3 PHASE MOTOR OF THE POWER UNIT DOES NOT ROTATE IN RIGHT DIRECTION (575 VOLTS). | 1. HAVE A CERTIFIED ELECTRICIAN TO VALIDATE THE DEFECT. |
| | | 2. THE LEVELLING VALVE AND/OR CHECK VALVE ARE NOT CLOSED PROPERLY. | 2.1 CLEAN RELEASE VALVE AND/OR CHECK VALVE. IF THE PROBLEM PERSISTS ; 2.2 REPLACE DEFECTIVE RELEASE VALVE AND/OR CHECK VALVE. |
| | | 3. THE LIFTING LOAD IS TOO HIGH. | 3.2 VERIFY THE TOTAL LOAD OF THE VEHICLE. 3.3 REDUCE VEHICLE WEIGHT (TOOLBOX, LOAD, ETC.) TO RESPECT THE LOAD RATE. |
| | | 4. THE MOTOR RUNS CORRECTLY, BUT THE PUMP DOES NOT PRIME. | 4.1 VERIFY THE OIL LEVEL IN THE TANK WHEN THE SWING ARMS ARE ON THE GROUND. ADD OIL AS NEEDED (1" FROM THE AERATOR PLUG). IF THE PROBLEM PERSISTS ; 4.2 REPLACE THE DEFECTIVE POWER UNIT. |
| 3 | THE SWING ARMS ARE DESYNCHRONIZED | 1. MALADJUSTMENT | 1. REFER TO SWING ARMS LEVELLING – OPERATING TESTS SECTION |
| | | 2. THE LEVELLING VALVE ONTO THE MASTER COLUMN IS NOT CLOSED PROPERLY. | 2.1 CLOSE THE LEVELLING VALVE AND LEVEL THE SWING ARMS. REFER TO SWING ARMS LEVELLING – OPERATING TESTS SECTION IF THE PROBLEM PERSISTS ; 2.2 REPLACE DEFECTIVE LEVELLING VALVE. CONTACT THE LIFT MANUFACTURER. |
| | | 3. SWING ARMS ARE DEFORMED | 3. REFER TO ANNEX 3 – ACCEPTABLE SWING ARMS DEFORMATION. |
| | | 4. SLAVE SWING ARMS COME TO THE GROUND BEFORE THE MASTER SWING ARMS. | 4.1 OPEN THE LEVELING VALVE. 4.2 ACTIVATE THE POWER UNIT TO LIFT THE SLAVE SWING ARMS TO THE SAME HEIGHT AS THE MASTER SWING ARMS. 4.3 CLOSE THE LEVELING VALVE. NOTE: CONTACT THE MANUFACTURER IF THE VEHICLE CANNOT BE LOWERED TO THE GROUND. |
| 4 | THE LIFT GOES DOWN WITHOUT TOUCHING CONTROLS | 1. THE RELEASE VALVE AND/OR CHECK VALVE ARE NOT SEALED. | 1.1 CLEAN RELEASE VALVE AND/OR CHECK VALVE. IF THE PROBLEM PERSISTS ; 1.2 REPLACE DEFECTIVE RELEASE VALVE AND/OR CHECK VALVE. |
| | | 2. THE LEVELLING VALVE ONTO THE MASTER COLUMN IS NOT CLOSED PROPERLY. | 2.1 CLOSE THE LEVELLING VALVE AND LEVEL THE SWING ARMS. REFER TO SWING ARMS LEVELLING – OPERATING TESTS SECTION IF THE PROBLEM PERSISTS ; 2.2 REPLACE DEFECTIVE LEVELLING VALVE. 2.3 CONTACT THE LIFT MANUFACTURER. |

MAN-NT-20000-SYM-C01-E

| # | PROBLEMS | CAUSES | SOLUTIONS |
|---|--|--|---|
| 5 | OIL LEAKAGE* | 1. SLAVE CYLINDER | 1. AN OIL OVERFLOW CAN BE OBSERVED ONLY ON THE SLAVE SIDE. THIS OVERFLOW CAN BE EXPLAINED BY THE FACT THAT THE CYLINDER SEALS CANNOT BE PERFECTLY SEALED. A SMALL AMOUNT OF OIL CAN ACCUMULATE IN THE INNER WALL OF THE CYLINDER AND CAN BE EVACUATED BY THE BREATHER (HOLE LOCATED AT THE TOP OF THE CYLINDER) AT RAISING WHEN THE LIFT REACHES A HIGHER HEIGHT THAN THE ONE NORMALLY USED. THE CYLINDER IS NOT DEFECTIVE. WIPE THE RESIDUAL OIL. NOTE : IF THE SWING ARMS LEVELLING IS FREQUENT, A REPAIR MUST BE PERFORMED. |
| | | 2. MASTER CYLINDER | 2. CONTACT LIFT MANUFACTURER. |
| | | 3. HYDRAULIC FITTINGS | 3.1 TIGHTEN THE LEAKING FITTING OF THE HYDRAULIC SYSTEM. IF THE PROBLEM PERSISTS ; 3.2 REPLACE LEAKING FITTING. |
| | | 4. AIR BLEEDER (SLAVE CYLINDER BASE) | 4.1 TIGHTEN THE LEAKING AIR BLEEDER. IF THE PROBLEM PERSISTS ; 4.2 REPLACE LEAKING AIR BLEEDER. NOTE : ADD TEFLON TAPE INTO THE TRAP THREADS OF AIR BLEEDER TO SEAL. |
| | | *NOTE : FOLLOWING AN OIL LEAK, VERIFY THE OIL LEVEL IN THE TANK WHEN THE SWING ARMS ARE ON THE GROUND. ADD OIL AS NEEDED (1" FROM THE AERATOR PLUG) AND LEVELED THE SWING ARMS : SWING ARMS LEVELING – OPERATING TESTS SECTION | |
| 6 | THE LIFT CANNOT RISE RATED LOAD | 1. THE RELEASE VALVE AND/OR CHECK VALVE ARE NOT CLOSED PROPERLY. | 1.1 CLEAN RELEASE VALVE AND/OR CHECK VALVE. IF THE PROBLEM PERSISTS ; 1.2 REPLACE DEFECTIVE RELEASE VALVE AND/OR CHECK VALVE. |
| | | 2. THE VEHICLE CENTER OF GRAVITY IS NOT CENTRED | 2. MOVE THE VEHICLE TO THE GROUND AND RECENTER THE CENTER OF GRAVITY. |
| | | 3. PRESENCE OF A LUBRICANT OTHER THAN TEFLON-BASED DRY LUBRICANT (E.G. GREASE) IN THE INSIDE CORNERS OF COLUMNS. | 3.1 CLEAN THE INSIDE SURFACES OF THE COLUMNS WITH A DEGREASER. 3.2 REFER TO LIFT CLEANING – MAINTENANCE AND INSPECTION INSTRUCTIONS SECTION. |
| 7 | THE LOAD HOLDING DEVICES DO NOT WORK AT THE DESCENT | 1. THE LOAD HOLDERS DO NOT MOVE FREELY. | 1.1 ACTIVATE THE POWER UNIT TO RISE THE LIFT OF 1" TO DISENGAGE THE STOPS BLOCKS FROM THE LOAD HOLDERS. 1.2 MANUALLY VERIFY THE MOVEMENT OF THE LOAD HOLDERS. 1.3 CLEAN OR RELEASE THE LOAD HOLDER. 1.4 REPLACE DEFECTIVE LOAD HOLDER. |
| | | 2. NO PNEUMATIC PRESSURE | 2. VERIFY IF THE PNEUMATIC SUPPLY IS FUNCTIONAL. |
| | | 3. AIR EVACUATES FROM PNEUMATIC TUBES. | 3. CUT OFF THE PIERCED PNEUMATIC TUBE PART. JOIN 2 HEALTHY PNEUMATIC TUBES BY USING AN AIR UNION. |
| | | 4. DEFECTIVE PNEUMATIC CYLINDER. | 4. REPLACE DEFECTIVE PNEUMATIC CYLINDER. |
| | | 5. DEFECTIVE PNEUMATIC VALVE (UNLOCKING VALVE) | 5. REPLACE DEFECTIVE PNEUMATIC VALVES (UNLOCKING VALVE). |
| 8 | THE LIFT IS INOPERATIVE IN RISE POSITION | 1. REFER TO PROBLEMS 1-7 OF THIS DOCUMENT | 1. IF THE PROBLEM PERSISTS AND CANNOT BE RELATED TO ANY OF THE PROBLEMS 1 TO 7 OF THIS DOCUMENT, CONTACT THE LIFT MANUFACTURER OR A LIFT PLANNED SERVICE PERSONNEL. |
| | | 2. LOW OIL LEVEL IN THE TANK. | 2. ADD OIL TO THE TANK. (1" FROM THE AERATOR PLUG). |
| | | 3. THE PRESSURE COMING FROM THE SLAVE HYDRAULIC CIRCUIT, SINCE THERE IS NO LOAD ON THE LIFT, IS INSUFFICIENT TO ACTIVATE THE PILOT VALVE IN DESCENT ONLY. THE SLAVE CARRIAGE IS LOWER THAN THE MASTER COLUMN ONE, WHILE THE MASTER CARRIAGE IS AT ITS MAXIMUM ELEVATION. | 3.1 OPEN THE LEVELING VALVE COMPLETELY. 3.2 ACTIVATE THE POWER UNIT BY PRESSING THE ON/OFF SWITCH OF THE POWER UNIT. ONLY THE SLAVE CARRIAGE WILL RISE. ONCE THE SLAVE CARRIAGE IS RAISED TO ITS MAXIMUM ELEVATION, HOLD THE ON/OFF SWITCH TO PUT THE PRESSURE BACK IN THE SYSTEM UNTIL THE MOTOR EMITS A NOISE INDICATING THAT IT HAS REACHED ITS FULL OPERATING PRESSURE (MAX 2 SEC). 3.3 CLOSE THE LEVELING VALVE COMPLETELY. NOTE: THE LEVELING VALVE MAY BE DIFFICULT TO CLOSE MANUALLY DUE TO THE HIGH HYDRAULIC PRESSURE IN THE SYSTEM. DO NOT USE PLIERS OR ANY OTHER INSTRUMENTS TO CLOSE THE LEVELING VALVE. 3.4 PRESS THE UNLOCKING VALVE AND THEN PUSH DOWN THE PRESSURE RELEASE HANDLE, BOTH PRESSING THEM TO LOWER THE SWING ARMS TO THE GROUND. 3.5 LEVEL THE SWING ARMS. SEE SWING ARMS LEVELING – OPERATING TESTS SECTION. |
| | | 4. THE LIFT INSTALLATION IS NOT ADEQUATE | 4. CONTACT THE LIFT INSTALLER OR THE LIFT MANUFACTURER. |

LOCKOUT/TAGOUT

REFER TO ANSI Z244.1

PURPOSE

THIS PROCEDURE ESTABLISHES THE MINIMUM REQUIREMENTS FOR THE LOCKOUT OF THE ENERGY THAT COULD CAUSE INJURY TO PERSONNEL BY THE OPERATION OF LIFTS IN NEED OR BEING SERVICED. ALL EMPLOYEES SHALL COMPLY WITH THIS PROCEDURE.

RESPONSIBILITY

THE RESPONSIBILITY FOR ASSURING THAT THIS PROCEDURE IS FOLLOWED IS BINDING UPON ALL EMPLOYEES AND SERVICE PERSONNEL FROM OUTSIDE SERVICE COMPANIES (I.E., AUTHORIZED LIFT INSTALLERS, CONTRACTORS, ETC.). ALL EMPLOYEES SHALL BE INSTRUCTED IN THE SAFETY SIGNIFICANCE OF THE LOCKOUT PROCEDURE BY THE FACILITY OWNER/MANAGER. EACH NEW OR TRANSFERRED EMPLOYEE ALONG WITH VISITING OUTSIDE SERVICE PERSONNEL SHALL BE INSTRUCTED BY THE OWNER/MANAGER (OR ASSIGNED DESIGNEE) IN THE PURPOSE AND USE OF THE LOCKOUT PROCEDURE.

PREPARATION

EMPLOYEES AUTHORIZED TO PERFORM LOCKOUT SHALL ENSURE THAT THE APPROPRIATE ENERGY ISOLATING DEVICE (I.E., CIRCUIT BREAKER, FUSE, DISCONNECT, ETC.) IS IDENTIFIED FOR THE LIFT BEING LOCKED OUT. OTHER SUCH DEVICES FOR OTHER EQUIPMENT MAY BE LOCATED IN CLOSE PROXIMITY OF THE APPROPRIATE ENERGY ISOLATION DEVICE. IF THE IDENTITY OF THE DEVICE IS IN QUESTION, SEE THE SHOP SUPERVISOR FOR RESOLUTION. ASSURE THAT PROPER AUTHORIZATION IS RECEIVED PRIOR TO PERFORMING THE LOCKOUT PROCEDURE.

SEQUENCE OF LOCKOUT PROCEDURE :

- 1) NOTIFY ALL AFFECTED EMPLOYEES THAT A LOCKOUT IS BEING PERFORMED AND THE REASON FOR IT.
- 2) UNLOAD THE SUBJECT LIFT. SHUT IT DOWN AND ASSURE THE DISCONNECT SWITCH IS "OFF" IF ONE IS PROVIDED ON THE LIFT.
- 3) THE AUTHORIZED LOCKOUT PERSON OPERATES THE MAIN ENERGY ISOLATION DEVICE REMOVING POWER TO THE SUBJECT LIFT.
 - 3.1 IF THIS IS A LOCKABLE DEVICE, THE AUTHORIZED LOCKOUT PERSON PLACES THE ASSIGNED PADLOCK ON THE DEVICE TO PREVENT ITS UNINTENTIONAL REACTIVATION. AN APPROPRIATE TAG IS APPLIED STATING THE PERSON'S NAME, AT LEAST 3" X 6" IN SIZE, AN EASILY NOTICEABLE COLOR, AND STATES NOT TO OPERATE DEVICE OR REMOVE TAG.
 - 3.2 IF THIS DEVICE IS A NON-LOCKABLE CIRCUIT BREAKER OR FUSE, REPLACE WITH A "DUMMY" DEVICE AND TAG IT APPROPRIATELY AS MENTIONED ABOVE.
- 4) ATTEMPT TO OPERATE LIFT TO ASSURE THE LOCKOUT IS WORKING. BE SURE TO RETURN ANY SWITCHES TO THE "OFF" POSITION.
NOTE : DO NOT FORGET TO PUT THE SWITCHES BACK IN "OFF" POSITION.
- 5) THE EQUIPMENT IS NOW LOCKED OUT AND READY FOR THE REQUIRED MAINTENANCE OR SERVICE.

RESTORING EQUIPMENT TO SERVICE

- 1) ASSURE THE WORK ON THE LIFT IS COMPLETE AND THE AREA IS CLEAR OF TOOLS, VEHICLES, AND PERSONNEL.
- 2) AT THIS POINT, THE AUTHORIZED PERSON CAN REMOVE THE LOCK (OR DUMMY CIRCUIT BREAKER OR FUSE) & TAG AND ACTIVATE THE ENERGY ISOLATING DEVICE SO THAT THE LIFT MAY AGAIN BE PLACED INTO OPERATION.

RULES FOR USING LOCKOUT PROCEDURE

USE THE LOCKOUT PROCEDURE WHENEVER THE LIFT IS BEING REPAIRED OR SERVICED, WAITING FOR REPAIR WHEN CURRENT OPERATION COULD CAUSE POSSIBLE INJURY TO PERSONNEL, OR FOR ANY OTHER SITUATION WHEN UNINTENTIONAL OPERATION COULD INJURE PERSONNEL. NO ATTEMPT SHALL BE MADE TO OPERATE THE LIFT WHEN THE ENERGY ISOLATING DEVICE IS LOCKED OUT.

WARRANTY POLICY

THE WARRANTY IS EXCLUSIVE TO THE ORIGINAL OWNER OF THE GIROLIFT AND IS NON-TRANSFERABLE. THIS WARRANTY IS VALID ONLY IF THE PRODUCT IS INSTALLED, OPERATED AND MAINTAINED TO THE INSTALLATION & OPERATING INSTRUCTIONS MANUAL AND ANSI/ALI ALOIM – « SAFETY REQUIREMENTS FOR OPERATION, INSPECTION AND MAINTENANCE » (LATEST VERSION). CANADA HYDRAULIQUE EQUIPEMENT INC RESERVES THE RIGHT TO DISCLAIM ANY RESPONSIBILITY FOR THE INSTALLATION OR REPAIRS THAT HAVE BEEN ATTEMPTED OR PERFORMED BY OTHERS. ANY MODIFICATION WITHOUT THE WRITTEN CONSENT OF CANADA HYDRAULIQUE EQUIPEMENT INC, MISUSE, DAMAGE, NEGLIGENCE OR IMPROPER USE COMPLETELY VOIDS THE WARRANTY.

THIS WARRANTY DOES NOT COVER NORMAL MAINTENANCE AND ADJUSTMENTS, NORMAL WEAR AND TEAR, LOSS OF PROFIT, LABOR AND TRANSPORTATION TIME FOR REPAIRS.

| | WARRANTY DURATION <i>FROM INVOICE DATE</i> | LABOR <i>FOR THE REPAIR</i> |
|---|---|--------------------------------|
| STRUCTURAL COMPONENT | 5 YEARS | 1 YEAR |
| FUNCTIONAL PART | 1 YEAR | |
| POWER UNIT | | |
| GIROLIFT BRAND ACCESSORY/ATTACHMENT | | |
| REPLACEMENT PART | 90 DAYS | N/A |
| NON GIROLIFT BRAND ACCESSORY/ATTACHMENT | 1 YEAR | |

NOTE : STRUCTURAL COMPONENT (CARRIAGE, FIXED POST, SWING ARM, RAMP), FUNCTIONAL PART (HOSE, PIPE, ADAPTER, SEAL, FITTING, VALVE, CYLINDER, SWING ARM RESTRAINT), ACCESSORY/ATTACHMENT (JIB CRANE, FORK LIFT ADAPTERS, ROLLING JACK, STRUCTURE, ETC.)

THE MODEL AND SERIAL NUMBER OF THE LIFT MUST BE PROVIDED WITH ANY CLAIM. IN CASE OF A POWER UNIT PROBLEM, THE MODEL AND SERIAL NUMBER OF THE POWER UNIT MUST BE ALSO PROVIDED.

TRAVEL FOR WARRANTY REPAIRS IS INCLUDED WITHIN RADIUS OF 100 KM FROM CANADA HYDRAULIQUE EQUIPEMENT INC PLANT. A PRE-DETERMINED RATE FOR ANY ADDITIONAL KM TRAVELLED AND PREAPPROVED WILL BE CHARGED TO THE CUSTOMER. ADDITIONAL CHARGES WILL APPLY FOR ANY REPAIRS MADE BY OUR TECHNICIAN THAT DO NOT RELATE TO THE WARRANTY ISSUE.

REPLACEMENT PART:

ALL CARRIER CHARGES ARE THE RESPONSIBILITY OF THE CUSTOMER. DEFECTIVE PART MUST FIRST BE SHIPPED TO OUR FACTORY FOR EXPERT EXAMINATION BY A CANADA HYDRAULIQUE EQUIPEMENT INC TECHNICIAN. ONCE THE DEFECT DIAGNOSTIC IS CONFIRMED, THE REPAIRED PART OR REPLACEMENT PART WILL BE SHIPPED TO THE COSTUMER. IF THE WAITING PERIOD DOES NOT PERMIT, THE REPLACEMENT PART WILL BE INVOICED AND PAID BEFORE BEING SHIPPED. A CREDIT WILL THEN BE ISSUED ON THE PART ONCE THE DEFECTIVE PART RETURNED TO OUR FACTORY AND IF THE PART INSPECTION IS PROVEN TO BE DEFECTIVE; THIS WARRANTY DOES NOT COVER NON DEFECTIVE PART OR MISDIAGNOSIS.

TO APPLY THE WARRANTY, THE INSTALLATION REPORT MUST BE SENT WITHIN 30 DAYS AFTER THE INSTALLATION OF THE GIROLIFT².

THE CURRENT WARRANTY PREDOMINATES OVER ALL DOCUMENTATION OR WARRANTY POLICY ISSUED PREVIOUSLY.

THE WARRANTY POLICY IS APPLICABLE ONLY IF THE NECESSARY REPAIRS, DAILY AND MONTHLY MAINTENANCE AND ANNUAL INSPECTION HAVE BEEN MADE IN ACCORDANCE WITH THE RECOMMENDATIONS OF CANADA HYDRAULIQUE EQUIPEMENT INC AND ANSI/ALI ALOIM. SUPPORTING EVIDENCE MAY BE REQUESTED.

CANADA HYDRAULIQUE EQUIPEMENT INC'S DECISION REPRESENTS THE FINAL AUTHORITY RESERVES THE RIGHT TO CANCEL THE GIROLIFT OWNER'S WARRANTY IF THE CONDITIONS ARE NOT MET.

² STANDARD FOR AUTOMOTIVE LIFTS – SAFETY REQUIREMENTS FOR INSTALLATION AND SERVICE (R2015), APPENDIX B : INSTALLATION REPORT.

PART LIST

NT-20000-SYM-C01 GIROLIFT

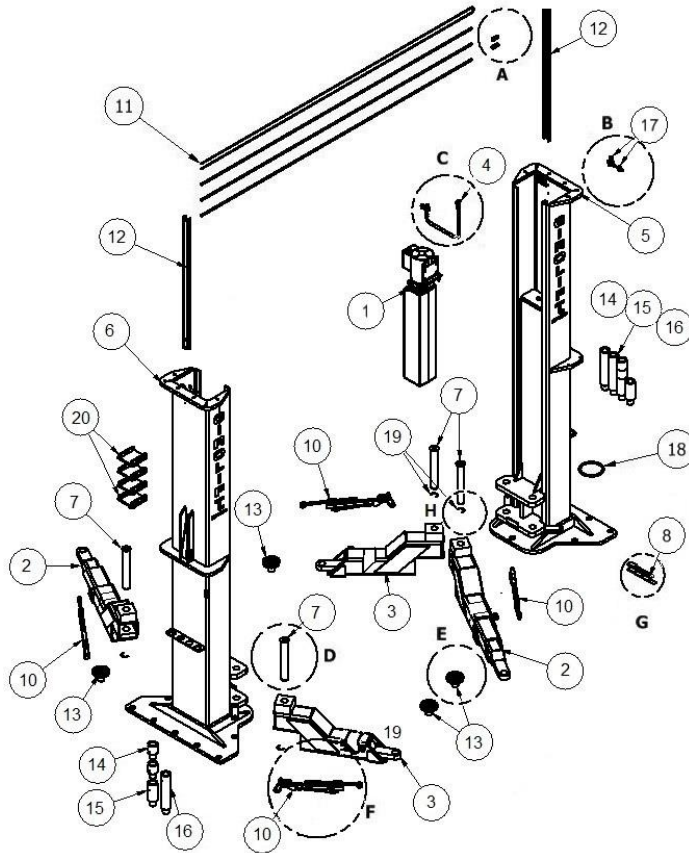

| DETAIL A | | DETAIL B | | DETAIL C | | DETAIL D | | DETAIL E | | DETAIL F | | DETAIL G | | DETAIL H | |
|----------|--|------------------|----------------|----------|---|-------------------------|--|----------|--|----------|--|----------|--|----------|--|
| 9 | | 17 | | 4 | | 7 | | 13 | | 10 | | 8 | | 19 | |
| # | DESCRIPTION | PART # | | # | DESCRIPTION | PART # | | | | | | | | | |
| 1 | POWER UNIT ASSEMBLED | 220 V | 20-00-13_0-R06 | 11 | 20-CHEC-A10-01 | 20-CHEC-A10-01 | | | | | | | | | |
| | | 575 V | 20-00-13_1-S06 | | CHM11-00625-0065-120000 | CHM11-00625-0065-120000 | | | | | | | | | |
| | | | | | TPU-02-NL-031 | TPU-02-NL-031 | | | | | | | | | |
| 2 | TELESCOPIC RIGHT ASSEMBLED SWING ARM 33" TO 65" LG | 20-BLTD-A01-01 | | 12 | 2" X 1" X 47" LG CHANNEL (WITH 2 X BOLT 3/8" X 1" LG AND 2 X NUT 3/8") | GEN-CCF-A01-01 | | | | | | | | | |
| 3 | TELESCOPIC LEFT ASSEMBLED SWING ARM 33" TO 65" LG | 20-BLTG-A01-01 | | 13 | ROUND AND GROOVED LIFTING PAD 1/2" X 5" DIA 3" HAUT – PIN Ø 2" X 5" LG 5000 LB CAPACITY | 20-ML500-A01-02-R | | | | | | | | | |
| 4 | ASSEMBLED Ø3/8" X 38" LG HOSE | BUH-06-38-A01-01 | | 14 | Ø 3" X 3" LG – PIN 2" LG EXTENSION SOCKET | RA30-03000-TS | | | | | | | | | |
| 5 | MASTER ASSEMBLED COLUMN | 20-C01-A01-C01 | | 15 | Ø 3" X 6" LG – PIN 2" LG EXTENSION SOCKET | RA30-06000-TS | | | | | | | | | |
| 6 | SALVE ASSEMBLED COLUMN | 20-C02-A01-C01 | | 16 | Ø 3" X 12" LG – PIN 2" LG EXTENSION SOCKET | RA30-12000-TS | | | | | | | | | |
| 7 | Ø2 X 14" LG SWING ARM PIN | 20-PBL-S01-01P | | 17 | Ø 1/8 AIR LINE CONNECTION "TEE INLET" | RLA-02-A01-01 | | | | | | | | | |
| 8 | 16 ANCHORS 3/4" X 7" LG AND SHIMS KIT | 20-KA-A01-01 | | 18 | 1/8" X 65' LG CLEAR POLYURETHANE TUBING | TPU-02-NL-065 | | | | | | | | | |
| 9 | TUBE 5/8" X TUBE 5/8" HYDRAULIC UNION | 7305-10-10 | | 19 | BLACK SNAP RING 2" SHAFT X 1.777" FREE DIAMETER | 0661-SNR2000200 | | | | | | | | | |
| 10 | 20" AUTOMATIC SWING ARM RESTRAINT | 20-BRA20-A01-01 | | 20 | SQUARED LIFTING PAD 6" X 6" X 4-3/8" – PIN Ø 2" X 2" LG 5000 LB CAPACITY | 20-ML750-A01-01 | | | | | | | | | |

MAN-NT-20000-SYM-C01-E

COLUMN

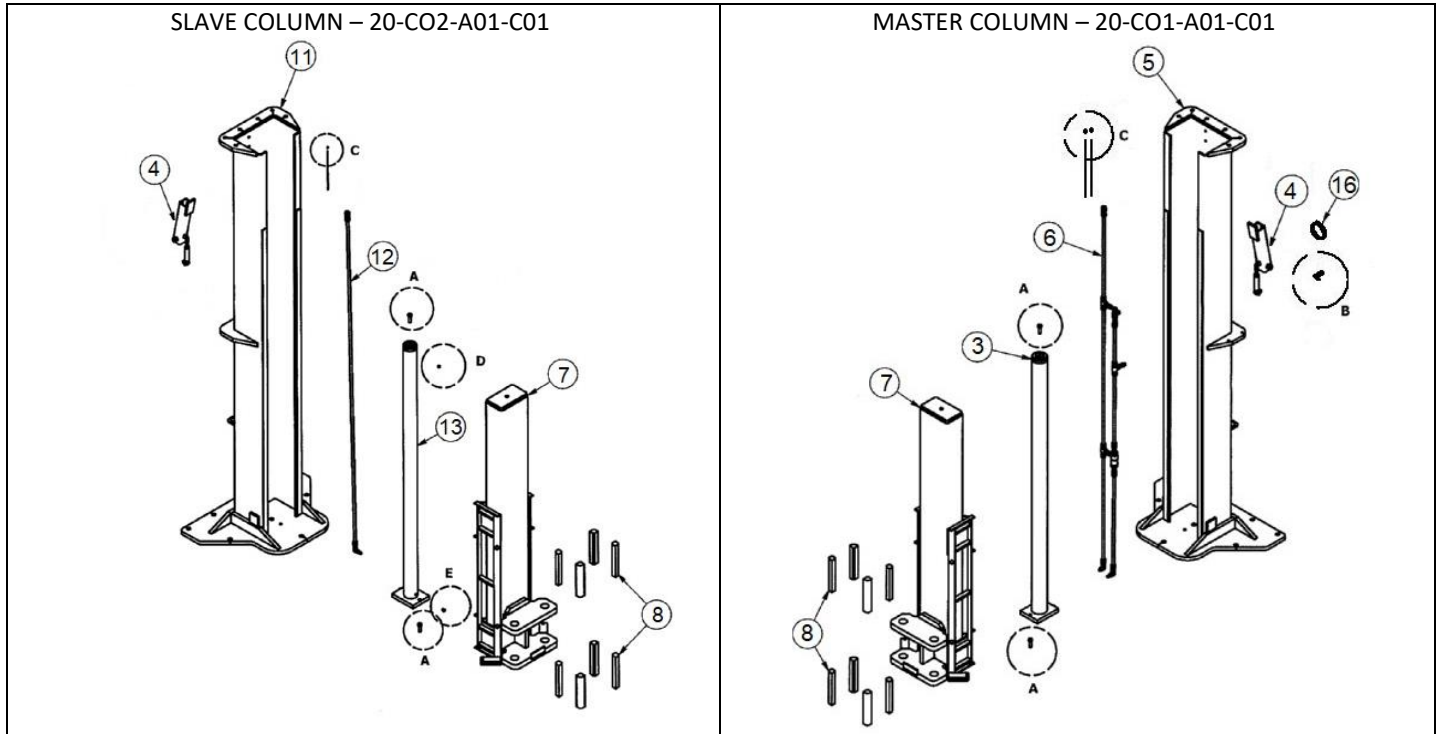

| DETAIL A | | DETAIL B | | DETAIL C | |
|----------|--|-------------------------|---|---|-------------------|
| | | | | | |
| # | DESCRIPTION | PART # | # | DESCRIPTION | PART # |
| 1 | AIR UNION FOR HOSE 1/8" OD (COMPOSITE) | CHE-UA02 | 5 | SLAVE ASSEMBLED CYLINDER | 20-CY2-A01-01P |
| 2 | MASTER ASSEMBLED CYLINDER | 20-CY1-A01-01P | 6 | SLAVE HYDRAULIC LINE | 20-CH2-FV8-A10-01 |
| 3 | MASTER HYDRAULIC LINE WITH PILOT VALVE | 20-CHP1-DF093-A10-06 | 7 | 1/8" PNEUMATIC VALVE | VPB-02-A01-03 |
| 4 | 1-1/2" x 1-1/2" x 9-7/8" LG UHMW BLOCK | BU61-01500-01500-009875 | 8 | RED COVER PROTECTION | 0609-C-36 |
| | | | 9 | LEVELLING VALVE 1/4" NPT (NEEDLE VALVE) | CHE-VA04 |

LOAD HOLDER

LIFTING ADAPTER

| DESCRIPTION | PART # | IMAGE | DESCRIPTION | PART # |
|--|---------------|-------|---|-------------------|
| PNEUMATIC CYLINDER 1-1/16" x 2" STROKE WITH 1/8" ELBOW | CPBU-A1063-02 | | GROOVED RUBBER PAD KIT Ø 5" (RUBBER, 3" BOLT AND NUT) | KRC-A0500-03000-R |
| | | | | |

CYLINDER

AUTOMATIC SWING ARM RESTRAINT

| # | DESCRIPTION | PART # | # | DESCRIPTION | PART # |
|---------------------------|--------------------------|----------------|--------------------------|----------------------------------|--------------------|
| 1 | MASTER CYLINDER SEAL KIT | SKC-15-CY1-A01 | 1 | 1/4 " X 2-1/16" ROD WITH THREADS | BRAD20-U0601-01-NF |
| 2 | SLAVE CYLINDER SEAL KIT | SKC-15-CY2-A01 | | | |
| | | | | | |
| MASTER ASSEMBLED CYLINDER | | | SLAVE ASSEMBLED CYLINDER | | |
| | | | | | |

POWER UNIT

| # | DESCRIPTION | PART # |
|---|------------------------------------|----------------|
| 1 | 220 VOLTS ASSEMBLED POWER UNIT – R | 20-00-13_0-R06 |
| 2 | 575 VOLTS ASSEMBLED POWER UNIT – S | 20-00-13_1-S06 |



220 VOLTS POWER UNIT – R

| # | IMAGE | DESCRIPTION | PART # | # | IMAGE | DESCRIPTION | PART # |
|---|-------|--|-----------------|---|-------|---|------------------|
| 1 | | ELECTRIC MOTOR FOR POWER UNIT WITH SWITCH 220/1/60 | MUH-220-1-60-R | 3 | | PRESSURE RELEASE HANDLE WITH MANUAL RELEASE VALVE | 0243-WX2-01-4010 |
| 2 | | CHECK VALVE | 0243-WG-05-1001 | | | | |

575 VOLTS POWER UNIT – S

| | | | | | | | |
|---|--|----------------------|--------------|---|--|---------------------|---------------------|
| 1 | | MANUAL RELEASE VALVE | 0243-VF-9021 | 5 | | 2507-AA CHECK VALVE | 0243-DCV-080-PB-N-5 |
|---|--|----------------------|--------------|---|--|---------------------|---------------------|

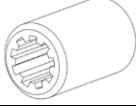
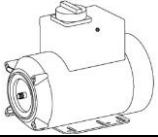
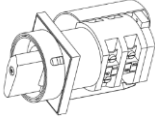
MAN-NT-20000-SYM-C01-E

| # | IMAGE | DESCRIPTION | PART # | # | IMAGE | DESCRIPTION | PART # |
|---|---|--|--------------|---|--|---|-----------------|
| 2 |  | PRESSURE RELEASE HANDLE WITH BLACK BALL | 0243-2565-AA | 6 |  | STARRY COUPLING 1.26" LG SAE 9T-20/40 | 0243-1118-AA |
| 3 |  | ELECTRIC MOTOR FOR POWER UNIT WITH SWITCH 575/3/60 HZ #2491-BC | MUH-575-3-60 | 7 |  | DRUM SWITCH 25A 15HP @ 600 VAC 575/3/60 | 0243-7GN2503U25 |
| 4 |  | DRUM SWITCH WITH COVER 25A 575/3/60 | 0243-W-138 | | | | |

LABEL

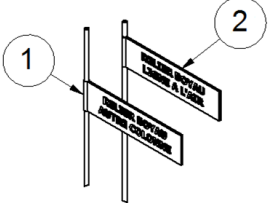
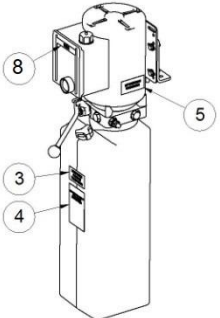
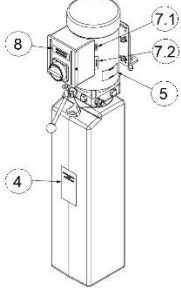
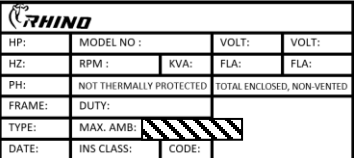
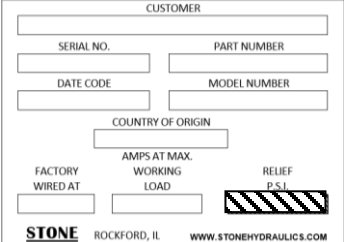
| IMAGE | # | DESCRIPTION | PART # |
|--|---|---|--|
|  | 1 | CONNECT PNEUMATIC HOSE TO OTHER COLUMN LABEL 6" LG X 3/4"HI | 0907-CHE-I-RELC |
| | 2 | CONNECT PNEUMATIC HOSE TO MAIN AIR LINE LABEL 7-1/2"LG X 1"HI | 0907-CHE-I-RELA |
| <div style="display: flex; justify-content: space-around;"> <div style="text-align: center;"> <p>220 VOLTS – R</p>  </div> <div style="text-align: center;"> <p>575 VOLTS – S</p>  </div> </div> | 3 | CONNECT TIME DELAY FUSES LABEL 2-3/4"LG X 1-1/2"HI | 0907-CHE-WL-FUSE |
| | 4 | RISK OF EXPLOSION/SHOCK LABEL 2-3/4"LG X 4-1/2"HI | 0907-CHE-WL-REC |
| | 5 | BREAKING SEAL LABEL 2-7/8"LG X 1-1/2"HI | 0907-CHE-WL-SEAL |
| | 6 | DUTY CYCLE 575 VOLTS LABEL 1-1/2"LG X 1/2"HI | 0907-CHE-G-DC575 |
| | 7.1 | 4 A LABEL 15/16"LG X 5/16"HA | 0907-CHE-I-4A |
| | 7.2 | DUTY CYCLE 575 VOLTS LABEL 1-1/2"LG X 1/2"HI | 0907-CHE-G-DC575 |
| | 8 | DIRECTION OF MOVEMENT 220 VOLTS LABEL 3-1/2"LG X 5/8"HI | 0907-CHE-I-MOV220 |
| | <div style="display: flex; justify-content: space-between;"> <div style="width: 48%;"> <p>POWER UNIT MODEL – R</p>  </div> <div style="width: 48%;"> <p>POWER UNIT MODEL – S</p>  </div> </div> | 9 | 3100 PSI LABEL 3/4"LG X 3/8"HA NOTE: AFFIX THE LABEL AT THE LOCATION INDICATED IN HATCHED ON POWER UNIT LABEL ACCORDING TO THE POWER UNIT MODEL. |

MAN-NT-20000-SYM-C01-E

| IMAGE | # | DESCRIPTION | PART # |
|---|----|--|---------------------------|
| <p>The image contains three technical drawings of a GIROLIFT column. The leftmost drawing shows a side view of the upper section with callouts 10 through 16. The middle drawing shows a side view of the lower section with callouts 17 through 25. The rightmost drawing shows a front view of the lower section with callouts 19 through 25. The drawings illustrate the placement of various safety and identification labels on the equipment.</p> | 10 | GIROLIFT USE LABEL 6-1/4"LG X 4"HI | 0907-CHE-I-UTG |
| | 11 | ALI LABEL - GOLD LABEL | 0907-ALI-GL |
| | 12 | NAME PLATE LABEL 2-7/8"LG X 2-1/2"HI | 0907-CHE-G-PSG |
| | 13 | ALI – NOTICE 4" LG X 5-3/4" HI LABEL | 0907-ALI-WL101-NOTICE |
| | 14 | ALI – AVIS 4" LG X 5-3/4" HI LABEL | 0907-ALI-WL101F-AVIS |
| | 15 | ALI – NOTICE 3"LG X 2-3/4"HI LABEL | 0907-ALI-WLSIA01-NOTICE |
| | 16 | ALI – AVIS 3"LG X 2-3/4"HI LABEL | 0907-ALI-WLSIA01F-AVIS |
| | 17 | VERTICAL GIROLIFT LABEL 4-1/8"LG X 34-3/4"HI | 0907-ALI-G-GVW |
| | 18 | NT-20000 LABEL 6"LG X 7/8"HI | 0907-CHE-G-NT20W |
| | 19 | LEVELLING VALVE LABEL 4-1/2" LG X 1-3/4"HI | 0907-CHE-G-VNIV |
| | 20 | ALI – CAUTION 10"LG X 25-1/2"HI LABEL | 0907-ALI-WL101-CAUTION |
| | 21 | ALI – WARNING 10"LG X 25-1/2"HI LABEL | 0907-ALI-WL101-WARNING |
| | 22 | ALI – MISE EN GARDE 10"LG X 25-1/2"HI LABEL | 0907-ALI-WL101F-MG |
| | 23 | UNLOCKING VALVE LABEL 3-1/2"LG X 1"HI | 0907-CHE-G-VDEB |
| | 24 | ALI – ATTENTION 10"LG X 25-1/2"HI LABEL | 0907-ALI-WL101F-ATTENTION |
| | 25 | LEVELLING ARMS LABEL 8-1/2"LG X 5-3/4"HI | 0907-CHE-I-NIV2 |

*** NOTE:** LABELS # 17 AND # 18 ARE FOUND ON THE 2 FACADES OF EACH OF THE MASTER AND SLAVE COLUMNS.

ANNEX 1

SAFETY SUPPLY

LIFT SAFETY LABELS

1. ALI/WL101 SECURITY LABELS:
 - CAUTION LABEL,
 - WARNING LABEL,
 - NOTICE LABEL.
2. ALI/WLSIA01 NOTICE LABEL.
3. CANADA HYDRAULIQUE EQUIPEMENT INC. LIFTING ARM LEVELING LABEL. SEE **FIGURE 22**.
4. NAME PLATE ON MASTER POST (WITH POWER UNIT). SEE **FIGURE 1**.
5. POWER UNIT IDENTIFICATION LABEL. SEE **FIGURE 2**.
6. CAUTION LABEL ON POWER UNIT. SEE **FIGURE 23**.
7. ALI SERIAL NUMBER LABEL.

| | |
|------------------|--|
| IMPORTANT | ALL LABELS #3 TO #25 FROM SECTION PART LIST – LABEL ARE REQUIRED. NOTE : REFER TO POWER UNIT MODEL FOR REQUIRED POWER UNIT LABELS. |
|------------------|--|



| NIVELAGE DES BRAS DE LEVAGE | INSTRUCTIONS | LEVELING OF LIFTING ARMS |
|---|---|---|
| SE RÉFÉRER AU MANUEL POUR L'IDENTIFICATION DES COMPOSANTES ÉNUMÉRÉES CI-DESSOUS. 1. Retirez manuellement les bras de levage au sol. 2. Descendez complètement les bras de levage au sol. 3. Sur la colonne maîtresse, ouvrez complètement la valve de nivelage. 4. Abaissez le poussoir de déchargement de pression sur l'unité hydraulique pour faire descendre les bras de levage complètement au sol. 5. Fermez complètement la valve de nivelage. ÉTAPE DE NIVELAGE 6. Activez l'unité hydraulique pour élever les bras de levage à environ 18" au-dessus du sol. Un cliquetement ou un grognement des butoirs doit se faire entendre. 7. Ouvrez complètement la valve de nivelage. 8. Abaissez la poignée de déchargement de pression pour faire descendre les bras de levage et faire engager les butoirs des colonnes mobiles sur les butoirs. 9. S'assurer que les butoirs des 2 colonnes mobiles soient correctement engagés sur les butoirs, appuyer sur la valve de déblocage pneumatique. * Si les butoirs restent engagés - les butoirs sont bien verrouillés, si les butoirs se débloquent, répétez le 6 et 7. 10. Élever au maximum les bras de levage. Voir Figure 1 . Essai de levage incliné doit être effectué à 14" (1" si le bras de levage maîtresse). Voir Figure 2 . * Si le bras de levage incliné est plus haut que celui du côté maître - communiquer avec le fabricant. 11. Activez l'unité hydraulique pour closer à 2 sec d'intervalle pour incliner le côté incliné jusqu'à ce que les bras des deux côtés soient à la même hauteur. 12. Fermez complètement la valve de nivelage. | REFER TO THE MANUAL FOR IDENTIFICATION OF LISTED COMPONENTS BELOW. 1. Remove lifting arm and socket adapters from the lifting arms. 2. Lower completely the lifting arms on the ground. 3. On the master post, fully open the leveling valve to the down pressure release handle of the hydraulic unit to lower the lifting arms completely. Close the valve. 4. Push down pressure release handle of the hydraulic unit to lower the lifting arms completely. Close the valve. LEVELING PHASE 6. Activate the hydraulic unit to raise the lifting arms approximately 18" above the ground (a clicking sound from the retractable load holders should be heard). 7. Open the leveling valve completely. 8. Push down pressure release handle to lower the lifting arms, so as to rest the stop blocks of the carriage directly onto the retractable load holders. 9. Make sure that the stop blocks of the carriage of both posts are correctly immobilized on the retractable load holders. Press the pneumatic release valve. * If retractable load holders remain immovable - the stop blocks are locked. * If retractable load holders move go back to step 6. 10. Raise the lifting arms as far as possible. See Figure 1 . * Side lifting arm must be 1/4" (or 1" lower than the master lifting arm. See Figure 2 . * If the side lifting arm is higher than the master side, contact the manufacturer. 11. Activate the hydraulic unit in short interval (2 sec) to raise the slave side until both sides are at the same height. 12. Close the leveling valve completely. | Figure 1  Figure 2  |

FIGURE 22 : LIFTING ARM LEVELLING LABEL

| | | |
|--|------------------|---|
| ⚠ | ATTENTION | ⚠ |
| L'UNITÉ HYDRAULIQUE A ÉTÉ AJUSTÉE EN USINE. LE BRIS DU SCAEU SUR L'UNITÉ ENTRAÎNERA L'ANNULATION DE LA GARANTIE. THE POWER UNIT HAS BEEN ADJUSTED IN THE FACTORY. BREAKING THE SEAL ON THE UNIT WILL VOID THE WARRANTY. | | |
| ⚠ | WARNING | ⚠ |

FIGURE 23 : CAUTION LABEL SAFETY SEAL

DOCUMENTS IN WORK BAY AREA

1. INSTALLATION AND OPERATION INSTRUCTIONS MANUAL OF LIFT MANUFACTURING.
2. "SAFETY TIPS" CARD: ANSI ALI-ST-17.
3. "LIFTING IT RIGHT" MANUAL : ANSI ALI/SM.
4. "QUICK REFERENCE GUIDE, VEHICLE LIFTING POINTS FOR FRAME ENGAGING LIFTS" : ANSI ALI/LP-GUIDE.
5. "STANDARD FOR AUTOMOTIVE LIFTS – SAFETY STANDARD FOR OPERATION, INSPECTION AND MAINTENANCE" MANUAL: ANSI/ALI ALOIM.

PROTECTION

1. LEVELLING VALVE PROTECTIVE COVER (RED) ON MASTER COLUMN. SEE **FIGURE 24**.
2. SAFETY SEAL ON PRESSURE REGULATOR CAP. SEE **FIGURE 25**.

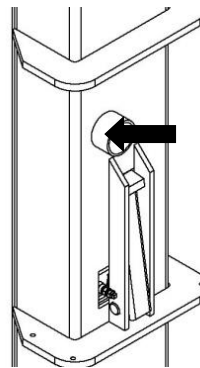

FIGURE 24 : PROTECTIVE COVER

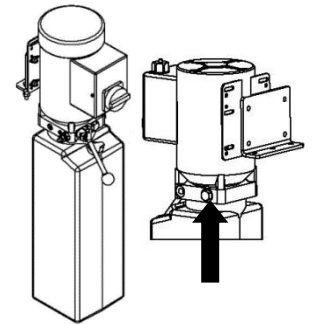

FIGURE 25 : SAFETY SEAL

ANNEX 2

USER MAINTENANCE FORM FOR 2 POST LIFT^{3*}

MODEL : _____
 SERIAL NUMBER : _____

INSTRUCTIONS

- NOTE DOWN THE MODEL, THE SERIAL NUMBER AND THE MONTH OF THE INSPECTION PERIOD.
- DAILY MAINTENANCE : NOTE "C" (COMPLY), "NC" (NOT COMPLIANT) OR "NI" (NOT INSPECTED) AND INITIALIZE IN APPROPRIATE BOXES OF THE DAY INSPECTED.
- IF IT IS NOT COMPLIANT OR ANY INTERVENTION HAS BEEN MADE, IDENTIFY IN THE NOTE SECTION THE ACTION TAKEN AND THE DATE.
- DO MONTHLY MAINTENANCE THE LAST DAY OF THE MONTH INSPECTED.

| # | DAILY MAINTENANCE DAY | MONTH : _____ | | | | | | | | | | | | | | | | | | | | | | | | | | | | | | |
|----------------|---|---------------|---|---|---|---|---|---|---|---|----|----|----|----|----|----|----|----|----|----|----|----|----|----|----|----|----|----|----|----|----|----|
| | | C / NC / NI | | | | | | | | | | | | | | | | | | | | | | | | | | | | | | |
| | | 1 | 2 | 3 | 4 | 5 | 6 | 7 | 8 | 9 | 10 | 11 | 12 | 13 | 14 | 15 | 16 | 17 | 18 | 19 | 20 | 21 | 22 | 23 | 24 | 25 | 26 | 27 | 28 | 29 | 30 | 31 |
| 1 | VISUAL COMPLIANCE OF ANCHORS | | | | | | | | | | | | | | | | | | | | | | | | | | | | | | | |
| 2 | VISUAL FLOOR COMPLIANCE | | | | | | | | | | | | | | | | | | | | | | | | | | | | | | | |
| 3 | VISUAL COMPLIANCE OF THE HYDRAULIC SYSTEM | | | | | | | | | | | | | | | | | | | | | | | | | | | | | | | |
| 4 | COMPONENT COMPLIANCE | | | | | | | | | | | | | | | | | | | | | | | | | | | | | | | |
| 5 | SWING ARM RESTRAINT COMPLIANCE | | | | | | | | | | | | | | | | | | | | | | | | | | | | | | | |
| 6 | BASE CLEANLINESS | | | | | | | | | | | | | | | | | | | | | | | | | | | | | | | |
| INITIAL | | | | | | | | | | | | | | | | | | | | | | | | | | | | | | | | |

| # | MONTHLY MAINTENANCE | COMPLIANT | TO IMPROVE | REPAIR NEEDED | COMMENTS |
|------------------------------|-------------------------------------|-------------|------------|---------------|----------|
| 1 | MECHANICAL COMPLIANCE OF ANCHORS | | | | |
| 2 | STRUCTURAL AND WELDING COMPLIANCE | | | | |
| 3 | SWING ARM DEFORMATION EVALUATION | | | | |
| 4 | LABELS AND DOCUMENTATION COMPLIANCE | | | | |
| 5 | LUBRICATION | | | | |
| LIFT OPERATIONAL TEST | | | | | |
| 6 | LOAD HOLDING DEVICES COMPLIANCE | | | | |
| 7 | COMPLETE CYCLE OF ELEVATION | | | | |
| MAINTENANCE DONE BY _____ | | (SIGNATURE) | | DATE _____ | |

| DATE | NOTE | DATE | NOTE |
|------|------|------|------|
| | | | |
| | | | |
| | | | |
| | | | |

CANADA HYDRAULIQUE EQUIPEMENT INC. RECOMMENDS INSPECTING THE GIROLIFT ANNUALLY BY A TRAINED AUTOMOTVE LIFT INSPECTOR.

*REFER TO INSTALLATION & OPERATING INSTRUCTION MANUAL SECTION MAINTENANCE AND INSPECTION INSTRUCTIONS FOR MORE DETAILS.

³ USER MAINTENANCE FORM FOR 2 POST LIFT AVAILABLE BY CONTACTING THE MANUFACTURER.

ANNEX 3

ACCEPTABLE SWING ARMS DEFORMATION

IMPORTANT

THE SWING ARM MUST BE REPLACED ENTIRELY FOR ANY MEASUREMENT NOT COMPLIANT BELOW.

STEP 1

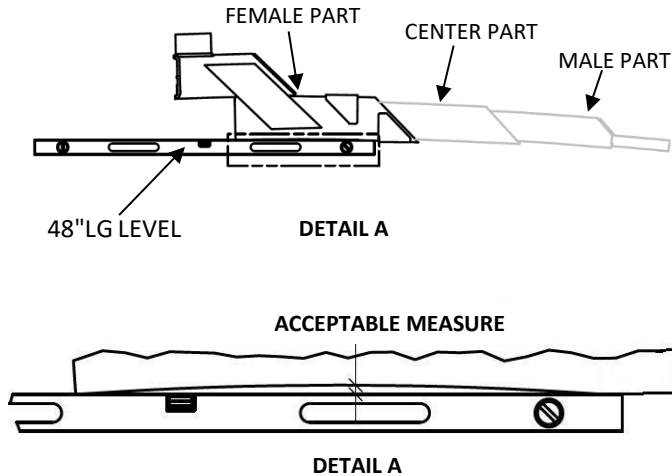

1. EXTEND THE SWING ARM TO MAXIMUM.
2. PLACE 48" LG LEVEL ON BOTH ENDS UNDER THE FEMALE PART OF THE SWING ARM.
3. MEASURE THE DISTANCE BETWEEN THE LEVEL AND FEMALE PART SURFACE OF THE SWING ARM.
4. REPEAT STEPS 2 AND 3 UNDER CENTER PART.
5. REPEAT STEPS 2 AND 3 UNDER MALE PART.

ACCEPTABLE MEASURE :
< 1/16"

STEP 2

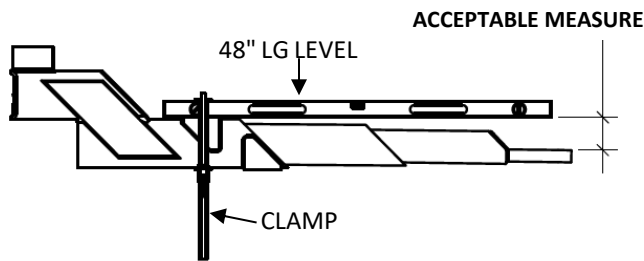

1. REMOVE LIFTING PAD AND EXTENSION OF SWING ARM.
2. EXTEND THE SWING ARM TO MAXIMUM.
3. PLACE LEVEL ON TOP OF THE FEMALE PART AND MAINTAIN IT WITH A CLAMP.
4. MEASURE THE DISTANCE BETWEEN THE LEVEL AND THE END OF THE MALE PART OF THE SWING ARM.

ACCEPTABLE MEASURE :
4-1/4" TO 4-3/4"

STEP 3

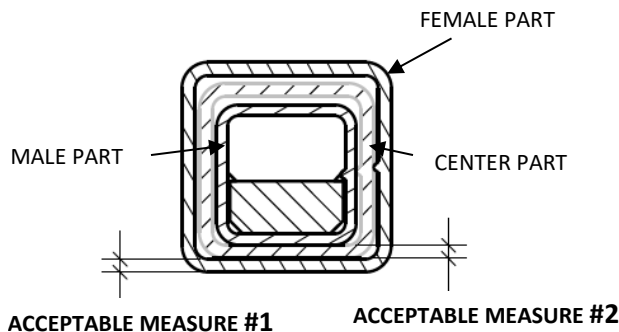

1. RETRACT SWING ARM EXTENSION TO MINIMUM.
2. MEASURE THE SURFACE OF FEMALE PART UNDER CENTER PART. (ACCEPTABLE MEASURE #1)
3. MEASURE THE SURFACE OF CENTER PART UNDER MALE PART. (ACCEPTABLE MEASURE #2)

ACCEPTABLE MEASURE #1 AND #2 :
5/16" TO 3/8"